

Back - to - basics

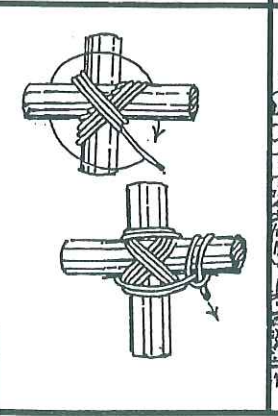
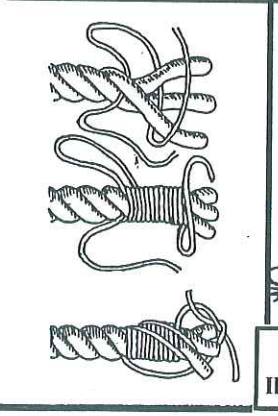
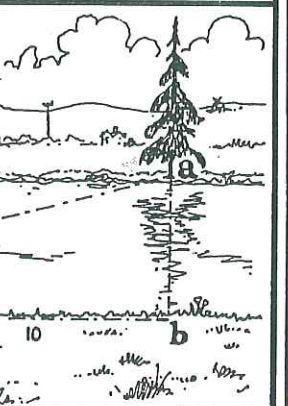
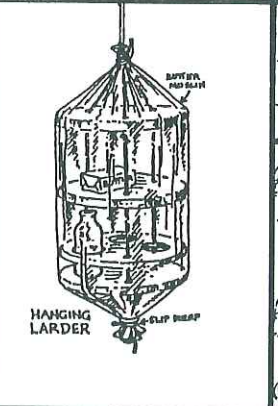
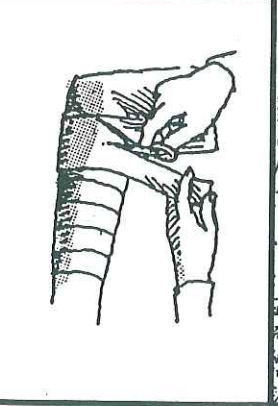
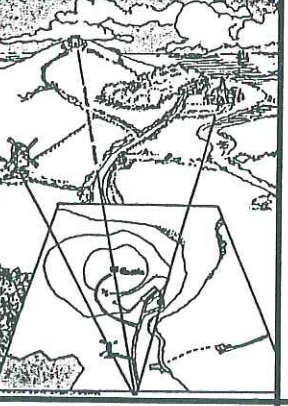
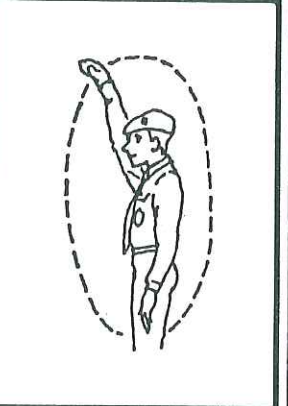
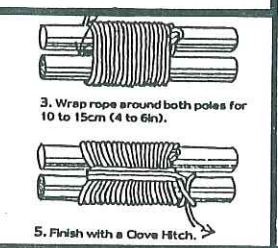
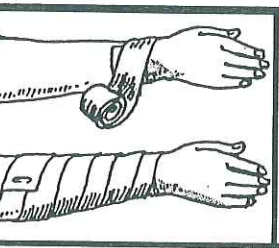
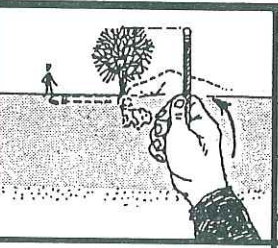
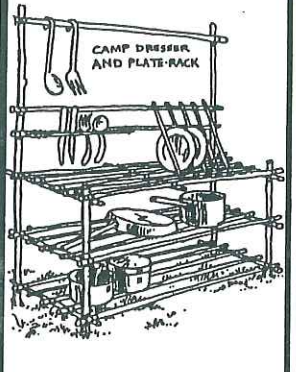
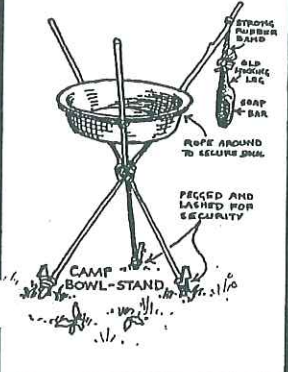

Written by Peter Brooks
Illustrated by Doug Mountford

Back - to - basics

Contents

Basic ... firelighting	5	Basic ... map reading IV	26
Basic ... types of cooking fire	6	Basic ... ways of finding your bearings	27
Basic ... wood burning properties	7	Basic ... knotting	28
Basic ... tent pitching	8	Basic ... lashings I	29
Basic ... bivouac building	9	Basic ... lashings II	30
Basic ... Patrol camp gear	10	Basic ... splicing	31
Basic ... Patrol camp layout	11	Basic ... rope-end whipping	32
Basic ... camp gadgets	12	Basic ... first aid I — Roller bandaging	33
Basic ... Patrol box/table	13	Basic ... first aid II — Slings and triangular bandages	34
Basic ... rucsac packing	14	Basic ... weather	35
Basic ... kit layout for inspection	15	Basic ... estimation	36
Basic ... flagpoles	16	Basic ... signalling	37
Basic ... flag practice I	17	Basic ... Troop control	38
Basic ... flag practice II	18	Basic ... Patrol corner and box	39
Basic ... axe safety	19	Basic ... B.-P. Part I	40
Basic ... food estimating	20	Basic ... B.-P. Part II	41
Basic ... steps to camp	21	Basic ... B.-P. Part III	42
Basic ... steps to camping abroad	22	Basic ... Brownsea Island	43
Basic ... map reading I	23	Basic ... Movement history	44
Basic ... map reading II	24	Basic ... Chief Scouts Part 1	45
Basic ... map reading III	25	Basic ... Chief Scouts Part 2	46

Foreword

There are many areas of Scoutcraft and lore that, while covered in a somewhat fragmented fashion in a variety of books and publications, are not drawn together in one place — *Back to basics* covers many of those subjects.

But before we get properly under way, a word of warning — many of the topics covered are practical skills which, to be mastered competently, need practical practise, they are not skills that can be learnt, properly, from a magazine or book. We present you with the information, the expertise, but it is up to you to practise and perfect the skills — no one else can do that for you.

Back - to - basics

Basic . . . firelighting

Lighting a fire is as easy as falling off a log! A slight over-simplification, perhaps, but basically true, provided you resist the temptation to collect a handful of sticks, drop them on the ground and shove a lighted match in — you *might* be lucky but it's very unlikely. The six steps detailed below will help you to build a fire properly and *know* that it will burn.

1. Carefully remove the turf from an area about a metre (3ft) square and push a twig into the ground in the middle. Store the turf, out of the way, and water regularly.



2. Surround the central twig with *kindling* — lots of small, dry twigs (hawthorn, fir and birch are best), pine needles, strips of silver birch bark or a pine cone or two.



3. Using progressively thicker twigs, build a wigwam-shape but leave a gap in the windward side so that you can place a match right into the kindling.

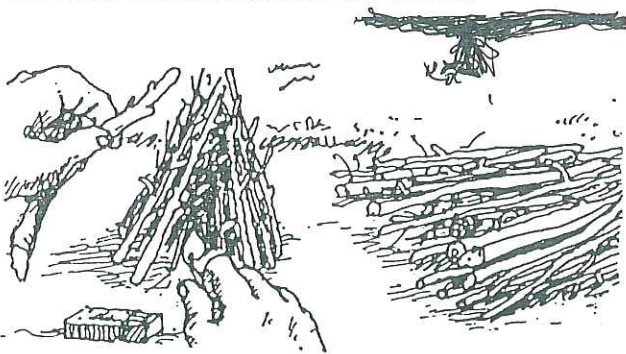

4. Light the kindling. If the wood is quite dry, the fire should take hold on its own but if not, blow *very gently*.



5. Add more tiny twigs to each flame, then, as your fire begins to grow, use larger and larger twigs then sticks.

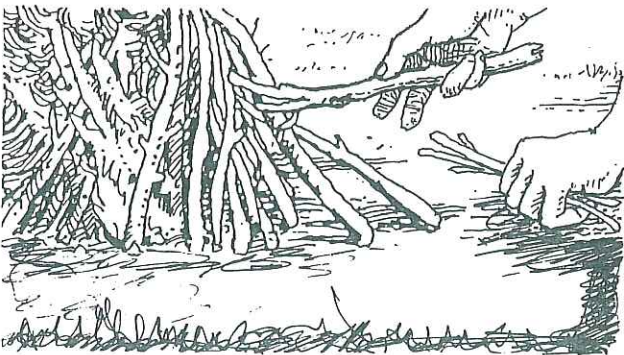

6. When firmly established, lay a log, parallel with the wind direction, on either side. Abandon the wigwam-shape by adding sticks, split logs and so on. Place a fire grill across the logs and, within a few minutes, your fire will be ready to commence cooking!

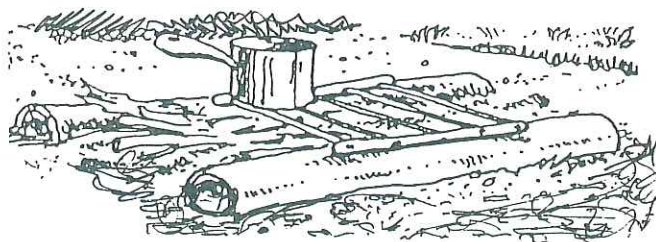

Infant fires can be fickle things — turn your back on them for just a few moments and they'll go out! The secret, then, is not to leave them unattended until they have 'grown up' but to do this you will have to have collected *all* the wood you will need (and that will be a considerable amount) before you even think of lighting the fire. Curb your impatience to strike the match until all the preparations are complete.

Written by Peter Brooks
Illustrated by Doug Mountford

Back - to - basics

Basic... types of cooking fire

In an earlier *Back to basics* we showed you how to lay and light a fire and suggested that, once the fire is established, you should lay logs on either side to support your fire grill or cooking pans. (*N.B.* These logs are often replaced with rocks (although these must not contain any moisture and should not be of sandstone as this can cause them to explode) or, more commonly, house-bricks can be used.) While this is quite correct, the matter is not quite as simple as that for there are, in fact, several other types of cooking fire which, on occasion, may be more suitable for your purposes.

The reflector fire

Still flanked by two logs, this fire is used to present indirect, rather than the usual direct, heat. Reflecting its heat off the log-screen, it is ideal for cooking fish or other such foods which could easily be spoiled if cooked directly over the fire. Alternatively, the addition of a U-shaped aluminium foil 'oven' will greatly expand the range of dishes you can produce.

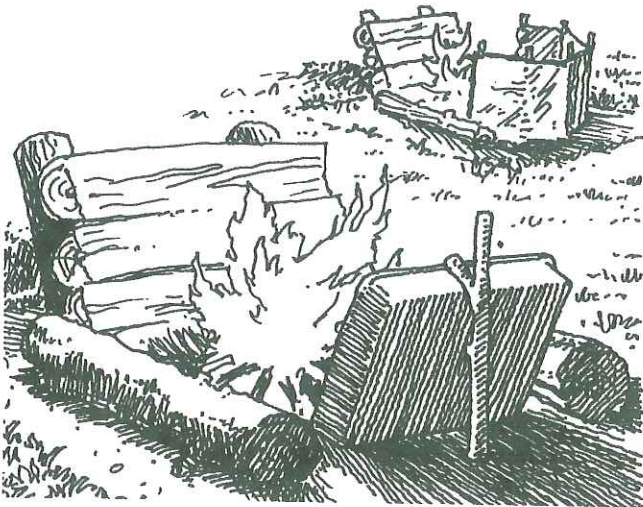

The star fire

Instead of having its logs placed along either side, this fire has three logs placed in a 'star' shape with the fire itself at the centre. As the logs burn away — rather more slowly than they do with the basic fire — they can be pushed in, and even replaced, with the minimum of difficulty.

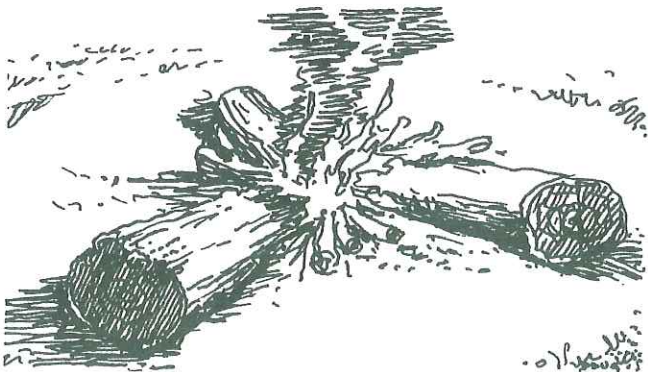

The altar fire

Probably the most popular fire nowadays, the altar fire (which is self-explanatory if you think about it) has the advantage that you don't have to keep bending down to tend and use it — everything is done standing up. If properly built (with interlocking logs, *sound* lashings or prepared angle-iron) these structures are safe and useful but if it is in any way rickety or otherwise unsafe *it can be extremely dangerous and must not be used*. It is advisable to use a thick metal sheet as the base-plate of your altar fire as (a) the fire cannot burn through (perhaps unnoticed until too late) and collapse with possible injury to the cook resulting, and (b) it prevents embers and hot ash falling through and setting fire to the grass below or igniting any wood you are drying/have stored underneath the structure.

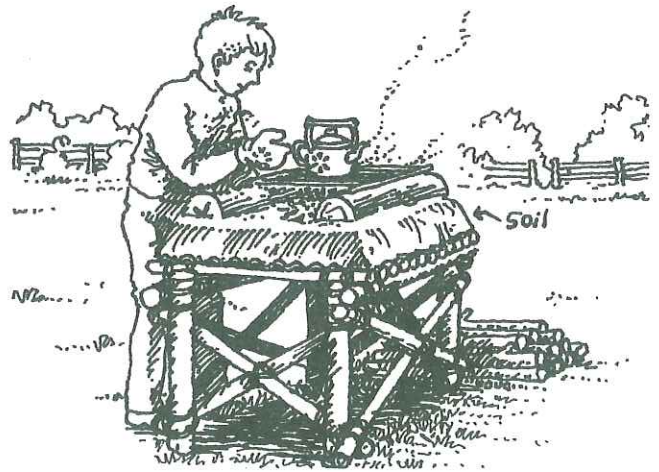

The trench fire

Carefully aligned so that it is parallel with the prevailing wind (and said wind can thus blow along it and aid the fire) this fire is at a disadvantage in that, if the wind moves round even slightly, you really need to dig a new trench!

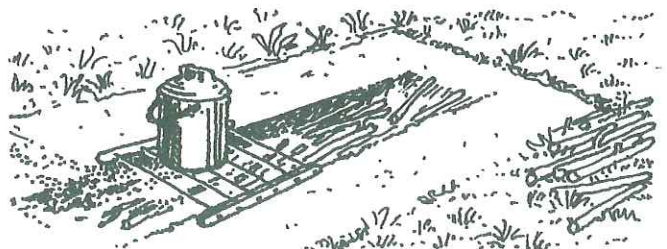







Written by Peter Brooks
Illustrated by Doug Mountford

Back - to - basics

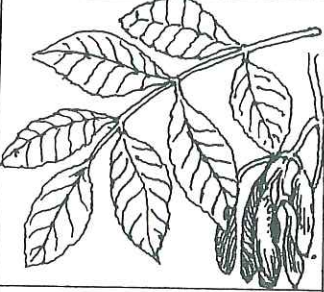
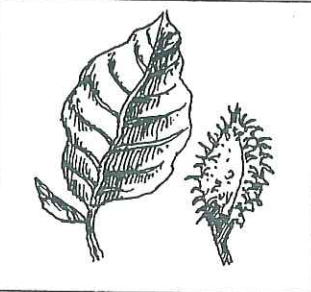
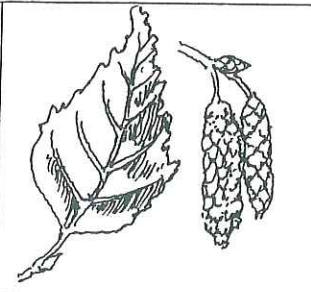
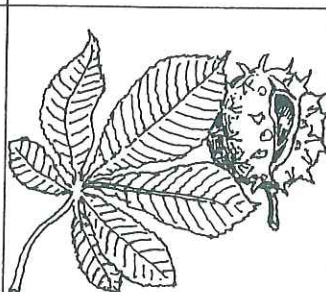
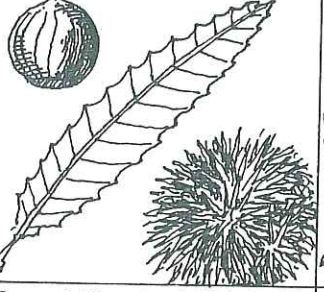
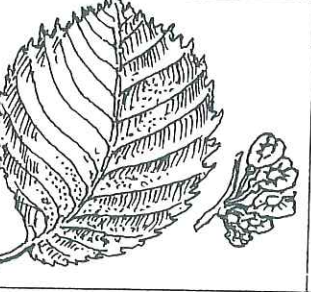
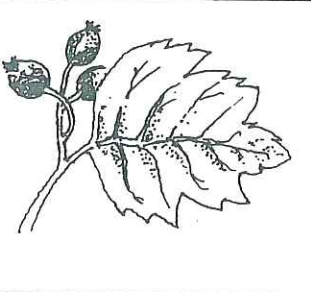
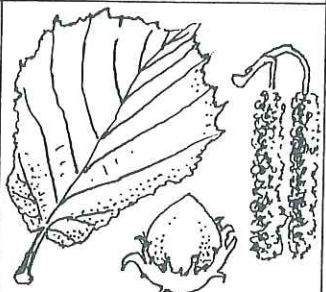
Basic . . . wood burning properties

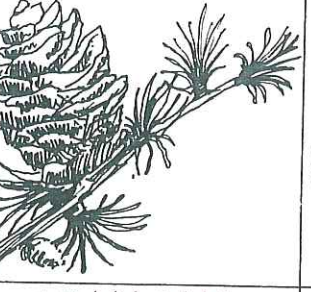
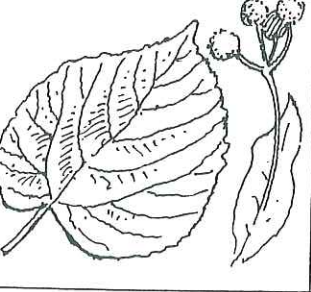
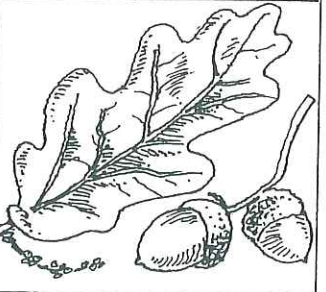
It would be easy to believe that 'wood' is 'wood' and that any piece will burn just as well as any other but, like so many things, it just ain't that simple! Most people know that some woods are softer than others and, to some extent, it is this that affects how they will burn. Likewise, most, but certainly not all, woods will burn better when they are dry while others will quite happily burn 'green'.

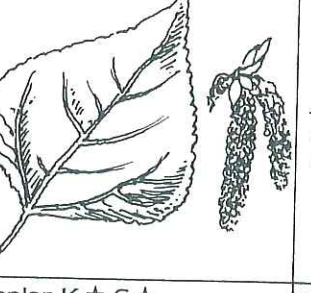
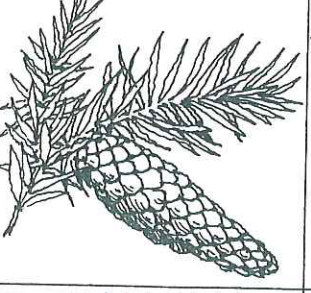
The following chart will probably help . . .

K = Kindling C = Cooking Good ★★★ Average ★★ Bad ★			
			
Ash K★★★ C★★★★	Beech K★★★ C★★★	Birch K★★★★ C★★★★	Horse Chestnut K★ C★
			
Sweet Chestnut K★ C★★★	Elm K★ C★	Hawthorn K★★★★ C★★★★	Hazel K★★ C★★
			
Holly K★★★★ C★★★★	Larch K★★★★ C★★★★	Lime K★★ C★★	Oak K★ C★★
			
Pine K★★★★ C★★★★	Poplar K★ C★	Spruce K★★★★ C★★★★	Sycamore K★ C★★

Written by Peter Brooks
Illustrated by Doug Mountford

BACK - to - basics

Basic... tent pitching

Going to camp is one of the main reasons why boys join the Scouts — the fun of living in a tent is unbeatable. Most Scouts will probably spend the majority of their nights under canvas in a ridged Patrol tent. There are several designs on the market but they are basically very similar in their pitching method and, having mastered one, you will be able to pitch any of them.

1. Lay out the groundsheet and peg the corners. Lay the tent, flat, alongside.

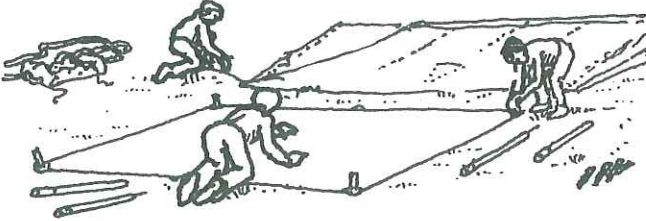

3. Knock in four large pegs. Lay out main guys on the ground (but clear of the groundsheet). Loosely loop the guys onto the pegs.

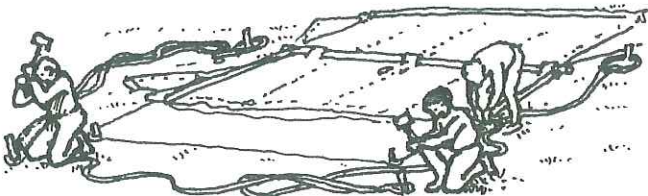

5. Lace up/tie tent doors closed. Peg out corner guys, then side guys. Insert brailing and door pegs. For a really neat appearance, side pegs should all align — attach a string between the corner guy pegs and peg side guys to this line then remove the string.

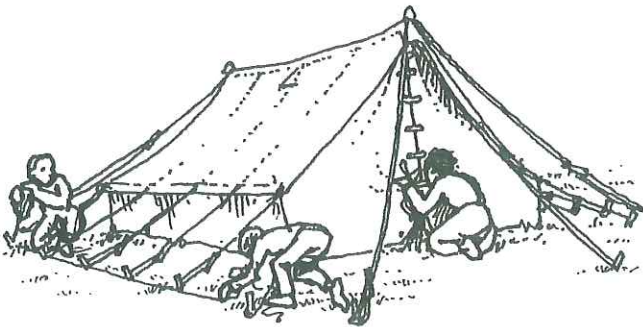

7. Adjust all guys so that the canvas is tight without being stretched.

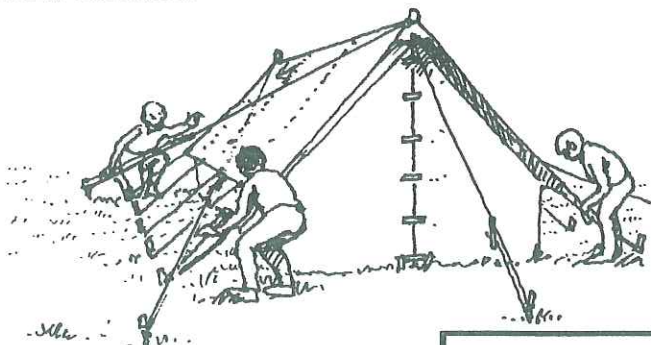

2. Open the tent, lay the ridge pole in position and insert the spikes on the upright poles through the holes in the ridge and the tent canvas.

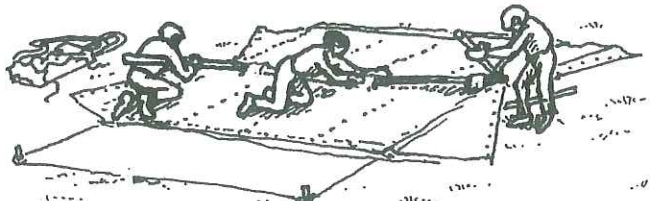

4. Raise the tent and position over groundsheet. Place main guy dollies onto the spikes and tighten guys.

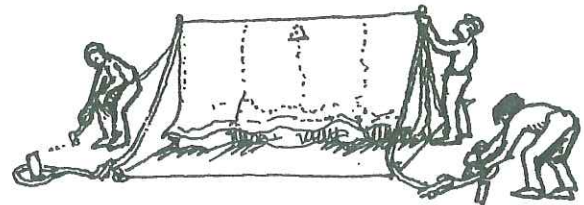

6. 'Storm rig' the tent by extending and crossing over the main guys. Relocate main guy pegs as necessary. (Storm rigging tidies the tent's appearance, keeps main guys close in to tent sides (therefore less trip-overable!) and makes it more secure in high winds as the ridge pole is taking the strain.) N.B. Do not attempt to storm rig a tent without a ridge pole — it won't work!

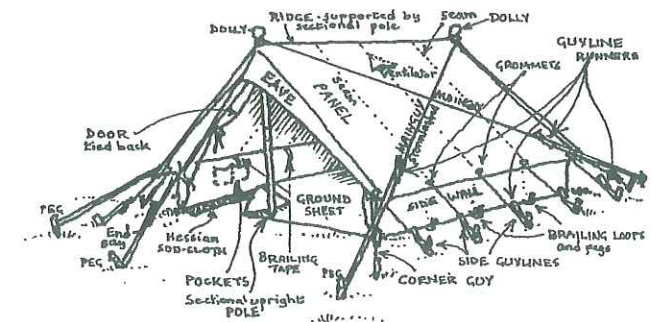
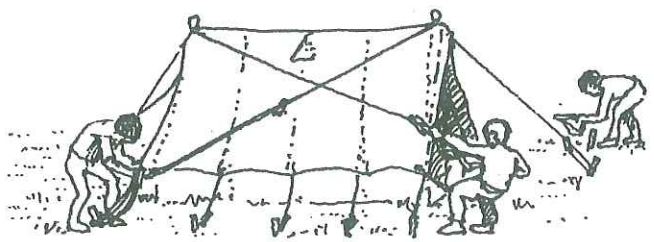

Written by Peter Brooks
Illustrated by Doug Mountford

BACK - to - basics

Basic... bivouac building

There will probably be occasions in every Scout's life when he will wish to go off hiking, carrying the absolute minimum of equipment. He will wish to test his survival knowledge — and win!

Although on many summer nights a shelter is not essential, the odd drop of rain has been known to fall now and again! In such circumstances, a shelter, built from materials found on site, can make all the difference between staying comfortable and dry and getting soaked to the skin and being utterly miserable!

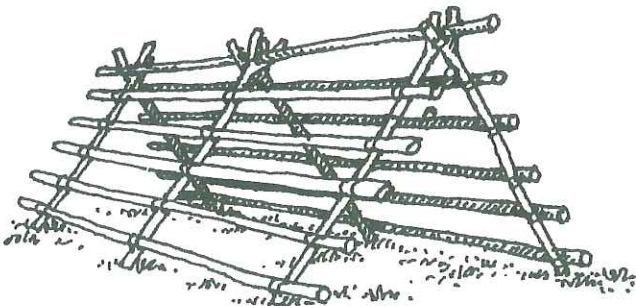

1. Construct two ladder-like frames that are about 60cm longer than you are tall but keep the rung-gap to about 8 to 10cm. Utilise any natural support that is available to support your ridge — this will save you work and make the structure more rigid.

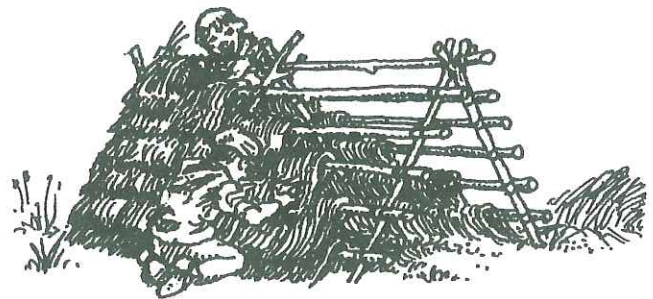

2. Starting at the bottom and working up a rung at a time, use long grass, bracken, reeds or leafy twigs (pine twigs and branches are good but you need an awful lot and they get very heavy) to make as thick a thatch as possible.

Points to remember...

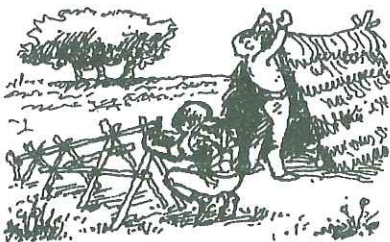

□ Without being silly about it, keep your bivouac as small as possible, it will be quicker and easier to build and you don't need acres of space just to sleep in!

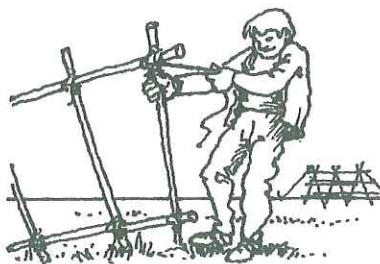

□ Any lashing will have to be very tight (to take the weight) or your shelter could collapse in the middle of the night!



□ Placing a 'baffle' log along the inner windward side will reduce any ground draught, thus helping you to keep warm.

□ If you are alone, a wedge-shaped bivouac will save you time and effort.



□ On a cycle-touring holiday your bike makes an ideal ridge support — but don't forget to guy it so it won't fall over.

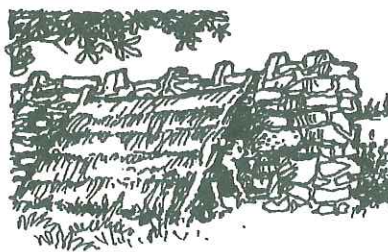

□ If there is a convenient wall, use it! Remember, too, to construct your bivouac on the sheltered (leeward) side, out of the wind.

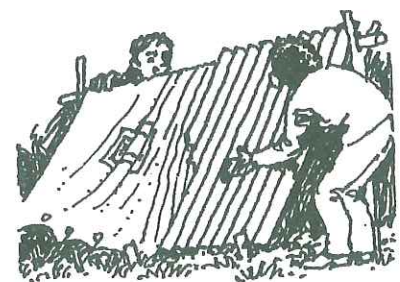

□ Use any old canvas, plastic or sheet of roofing material that you find.

□ To achieve a weather-proof thatch it needs to be extremely thick and closely-packed and for that you will have to have a very good supply of thatching material and a lot of time.

Written by Peter Brooks
Illustrated by Doug Mountford

Back - to - basics

Basic . . . Patrol camp gear

It would be accurate to say that one of the most popular reasons for joining 'the Scouts' is to go camping. (Our young people certainly don't join to be shaped into better citizens! And most don't even realise that this is going on — or they shouldn't if your programme is right!) Occupying such an important place in the scheme of things as camping does, it becomes incumbent upon us, as Leaders, to ensure that the camping skills we pass on are both correct and all-encompassing.

Knowing what equipment to take — and, just as important, what *not* to take — is as necessary as knowing where to go, how to arrange the programme and menu, what safety precautions to take and so on.

What equipment the Patrol takes away will, of course, vary with the programme they are following but listed below are most of the things that a Patrol is likely to need during a standing (as opposed to a back-packing or mountain-walking) camp.

Main site equipment

Patrol tent, groundsheet, poles, guys, pegs, mallet;
Cooking and dining shelters, poles, guys, pegs;
Sisal and rope for gadgets;
Patrol box converting to table,
Handaxe or bushsaw, lamp,
Flags, halliards, flagpole.

Equipment for latrines (unless permanent ones on site)

Latrine screening, poles, guys, pegs;
Toilet paper in waterproof container;
Trowel, washbowl, soap, towel,
Pickaxe, shovel.

Cooking equipment

Large dixie, teapot,
Nest of billies,
Frying pan,
Water carriers,
Baking and serving dish,
Wooden spoon, soup ladle,
Vegetable preparation knife, fork,
Potato peeler, tongs, oven gloves,
Fish slice, tin opener, bottle opener,
Plastic bags, aluminium foil, butter muslin,
Pudding cloth, paraffin stove or gas stove,
Paraffin and meths, or spare gas cylinders,
Food as necessary for menu.

Emergency equipment

First aid box (properly stocked),
Spare airbed/campbed, blankets,
Lamp and torch.

Special activity and games equipment

Take whatever your programme requires.
Don't forget any necessary emergency
rations and life-saving equipment.

General neatness

Suitcase for storing uniforms,
Coathangers, mirror, shoe cleaning
equipment, mending materials.

Washing and washing-up equipment

Wash bowls, bucket,
Washing-up liquid,
Dish cloth, tea towel,
Mop, scrubbing brush and abrasive pads,
Plastic draining rack.

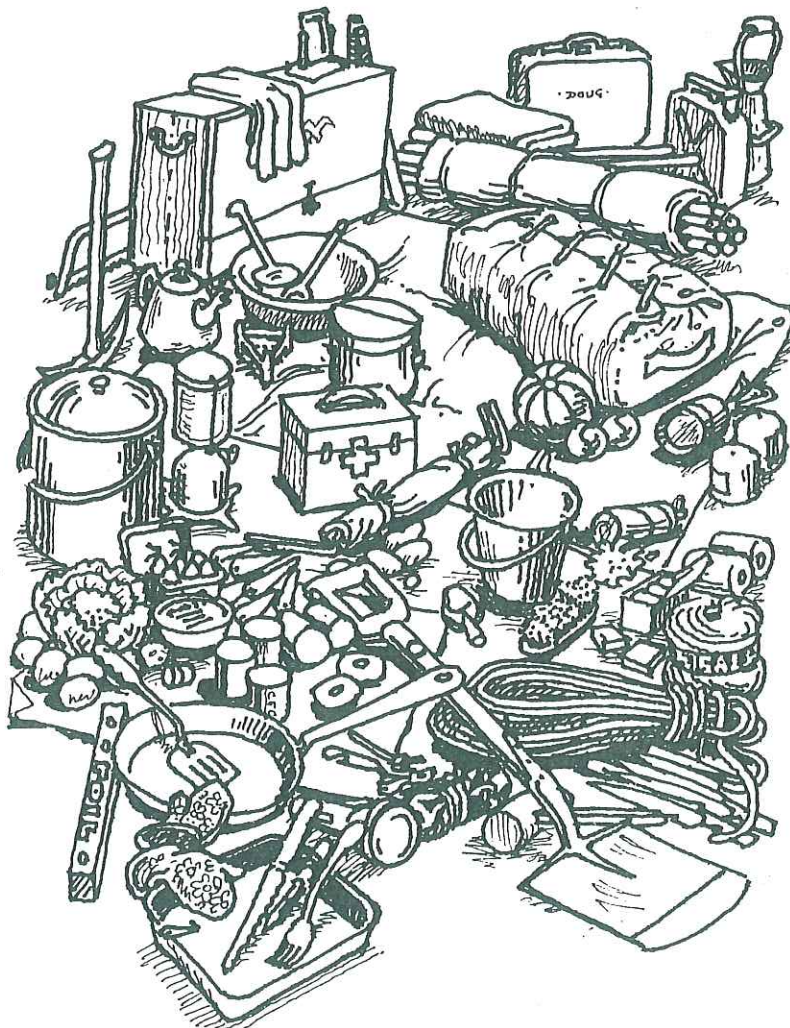

Written by Peter Brooks
Illustrated by Doug Mountford

Back - to - basics

Basic... Patrol camp layout

It is not difficult to suggest a 'perfect' layout for a Patrol camp site — that, indeed, is the easy bit — the difficulty comes in trying to translate that to suit the site you will be camping on. If the site is popular, you might not have quite as much room as you would like, the slope of the ground might dictate where you can or can't pitch the tent, the prevailing wind might be coming from the wrong direction or, without doubt, at least one tree will be in the wrong place — in fact, it can be any one of a number of reasons.

Pictured below is one of many 'perfect' layouts and although it is unlikely that you will ever have enough room to spread yourself like this Patrol, it is a good idea to keep a layout like this in your mind's eye so that you can get as close to it as you can.

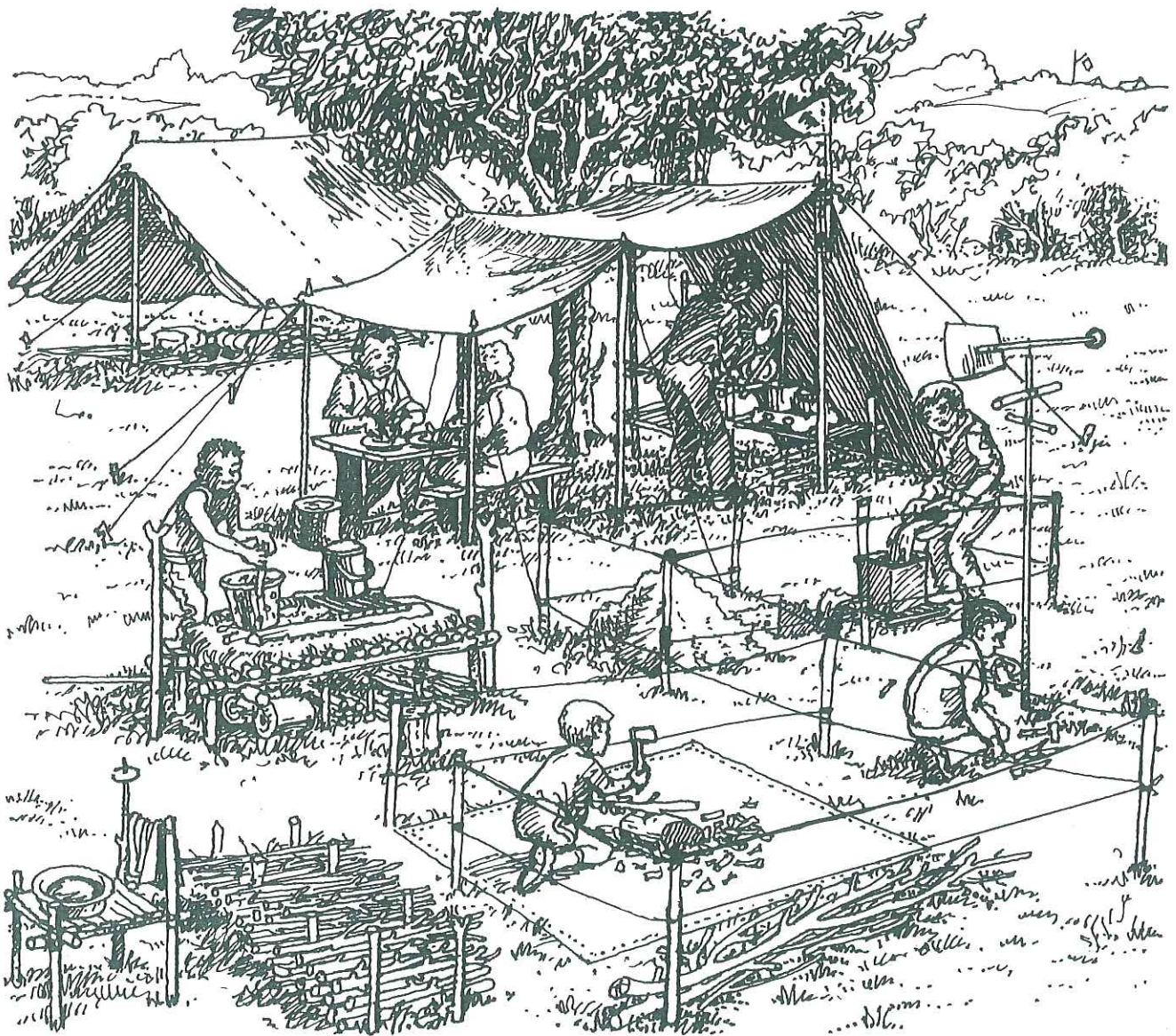

Ideally, you want... a large, flat open area that is screened, all around, with bushes... the next Patrol should be out of both sight and ear-shot... your fire should be located on the down-wind side so that the smoke is blown away... the water tap is handy... there is some shade in which to hang your larder... there is a plentiful and close supply of wood... toilets nearby (without being too close!). This list can go on and on... what additions would you make?

Written by Peter Brooks
Illustrated by Doug Mountford

Back - to - basics

Basic . . . camp gadgets

Time was when, at camp, as soon as the tent was pitched and personal gear stowed away, everyone would turn to and start constructing gadgets all over the place. There were gadgets for this and gadgets for that, in fact, you name it and there was a gadget for it! Whilst all this industry was highly laudable, you might be forgiven for wondering if many of the constructions were essential or merely desirable and built more as a pastime.

Today's Scouts, however, seem to be able to find dozens of other activities with which to fill their days. In all fairness, some gadgets do still have a purpose and time spent in their construction will make the campers' lives more comfortable and enjoyable.

Shown here are some of those that will still enhance the modern camp.

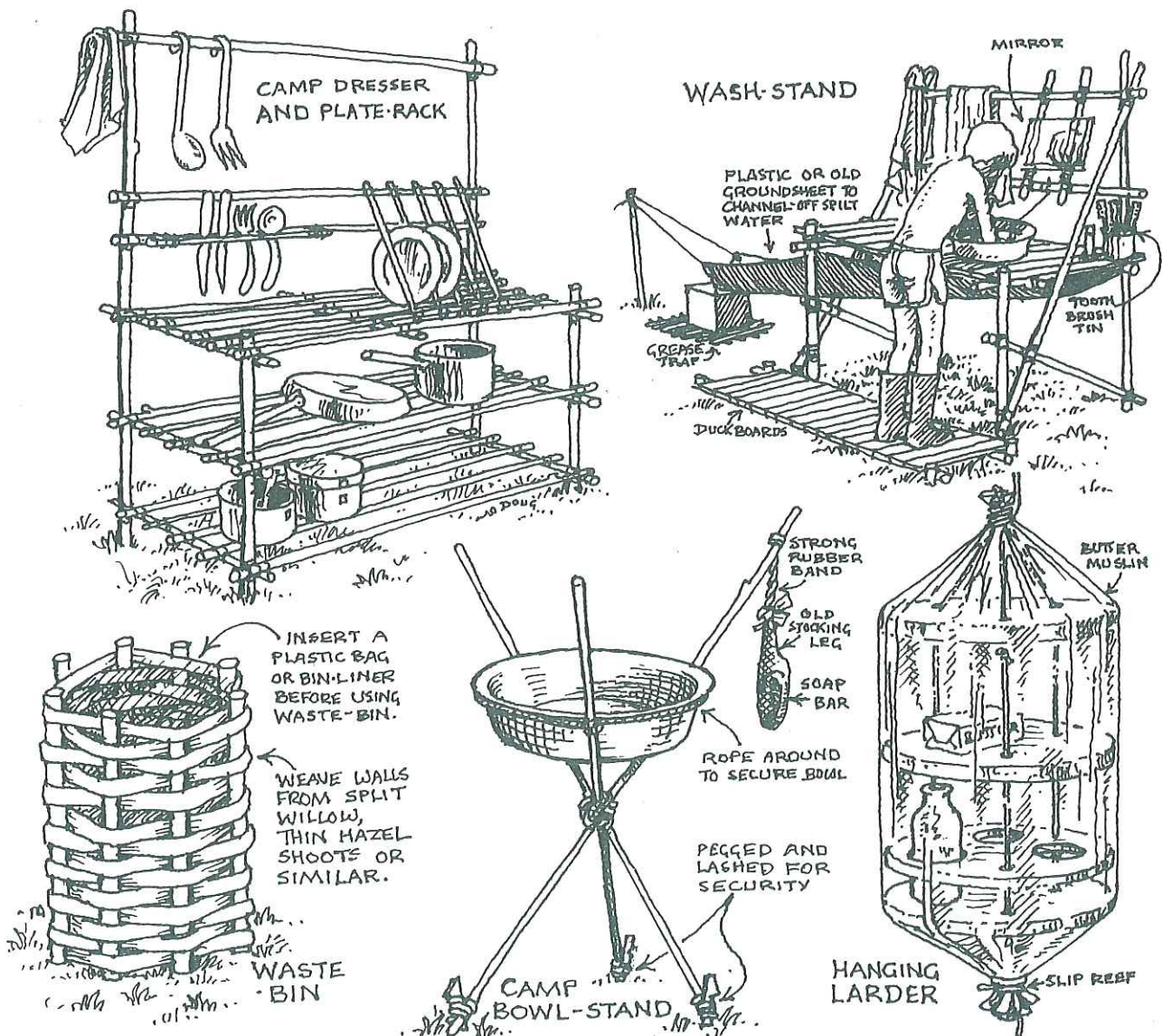

Tip: With either of the above wash-stands, the soap is always on hand if you place a bar in the foot of an old stocking and suspend this with a thick rubber band from the top of one pole. To use, pull the soap into the water and wash your hands. After use, release the soap and the retracting band will withdraw the soap and stop it going soggy in the bottom of the bowl.

Written by Peter Brooks
Illustrated by Doug Mountford

Back - to - basics

Basic... Patrol box/Table

Most youngsters going away to camp with the Scouts for the first few times are usually quite happy to 'rough it' — that's part of the fun! But basic creature comforts soon make their absence felt and it is not long before the realisation dawns that, with a comparatively small amount of effort, life can be made both easier and a great deal more comfortable.

Altar fires are a good example of this, as the fire is then brought to a convenient height, thus saving all that bending down! Wash-stands and camp dressers perform a similar function. Tables and chairs often follow close behind and, with this in mind, we offer the following as an excellent example of ingenuity. In its closed state, it is a useful box capable of storing quantities of either equipment or food provisions but, opened out, it turns into a table with two benches.

The measurements shown are for guidance only and can be varied to suit your own needs but remember, once loaded the box must at least be movable!

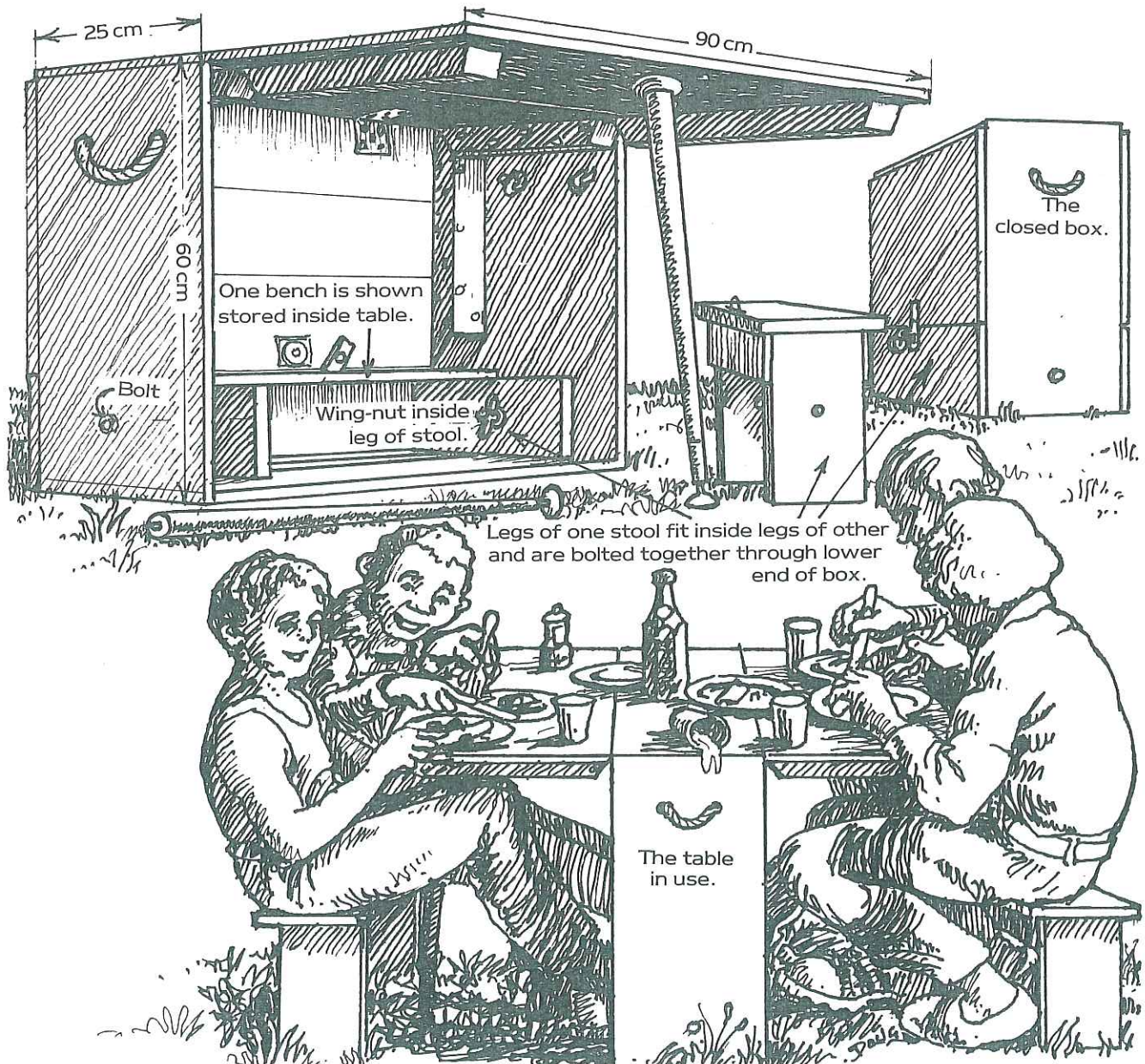

Written by Peter Brooks
Illustrated by Doug Mountford

Back - to - basics

Basic... rucsac packing

See a young Scout going to his first camp and, apart from an overflowing enthusiasm and keenness to get there, you probably won't notice anything out of the ordinary.

However, view the same lad on his way home and you'll notice a distinct difference! He will probably be clean (I emphasise the *probably* and then only on the bits of him that show!) and he may be fairly tidy in appearance but his kit, and particularly his rucsac, will bear more than a passing resemblance to a Christmas tree! Items of clothing will be issuing from every orifice, his mug, boots and anything else that will hang, will be suspended from any available anchorage and his sleeping bag will probably be making a determined effort to escape from its less-than-adequate securing strings!

For some reason the Movement seems to have lost the ability to teach its young Members how to pack a rucsac — regrettable but true.

The illustration below will, we hope, help to rectify this — all it takes is a little practise.

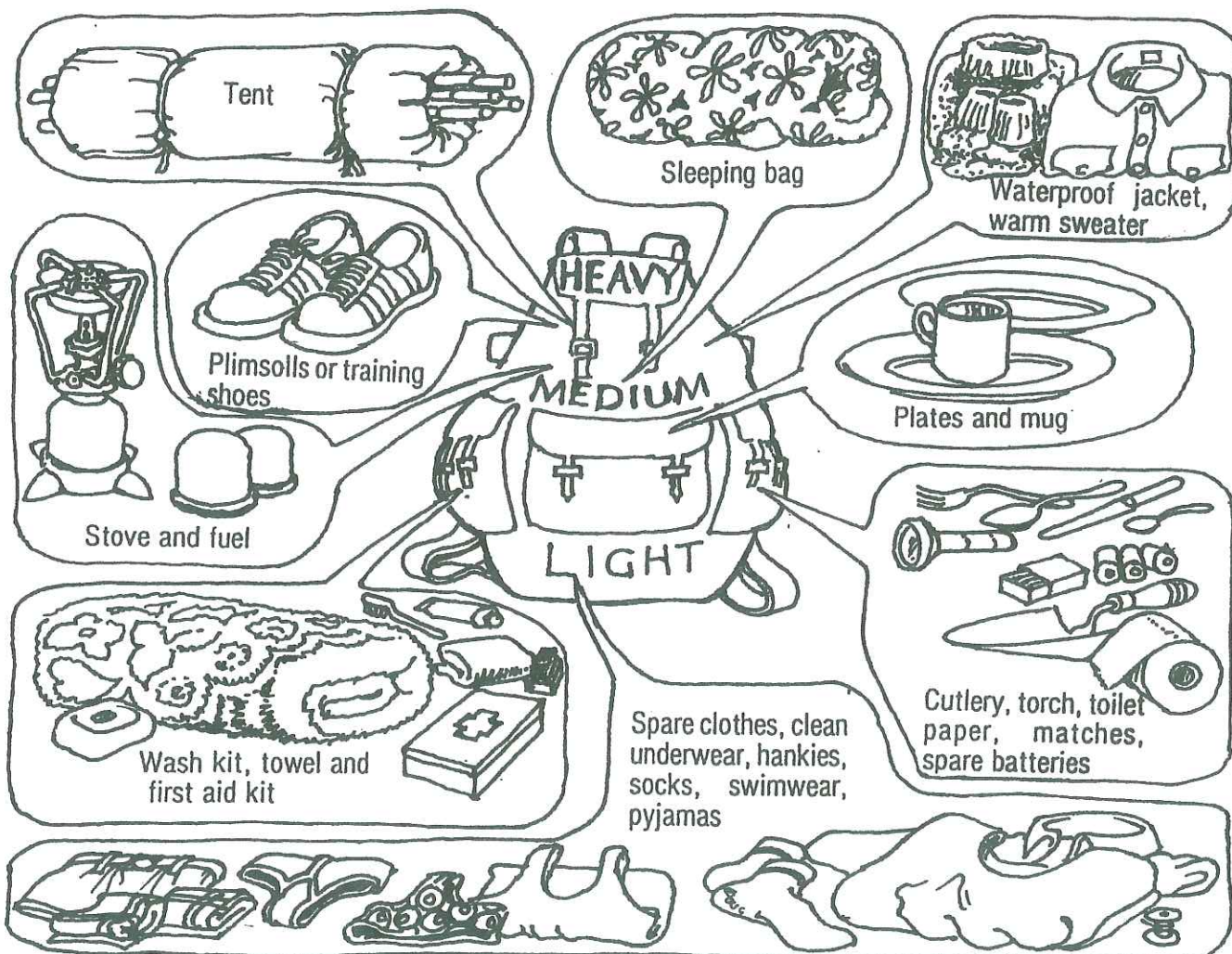

Points to remember:

- Pack the side-pockets first. You'll get more in them then and it will be easier than when the main sac is full.
- Pack *first* the things you will need *last* and *vice versa*.
- By placing a dustbin bag inside your rucsac first and packing into this, your kit should stay dry in even the wettest weather.
- Keep your wet weather clothing easily accessible in case of a sudden shower.
- If you always pack your gear in the same places in your rucsac you will always know precisely where to find each item as you want it.

Written by Peter Brooks
Illustrated by Doug Mountford

Back - to - basics

Basic... kit layout for inspection

Mention 'kit inspection' to most youngsters at camp and you'll be met with groans and mutterings of ill-will. What they fail to appreciate, however, unless it is explained to them, is that far from being just a chore designed to interrupt their day, it is, in fact, a chance for them to make sure that they still have all their kit and that it is in good order. After all, living in a tent, usually in fairly poor lighting, it is very easy for the odd sock or t-shirt, for instance, to find its way purely by accident into someone else's rucksac. Regular kit inspection, outside on all occasions unless it is actually raining, presents the answer.

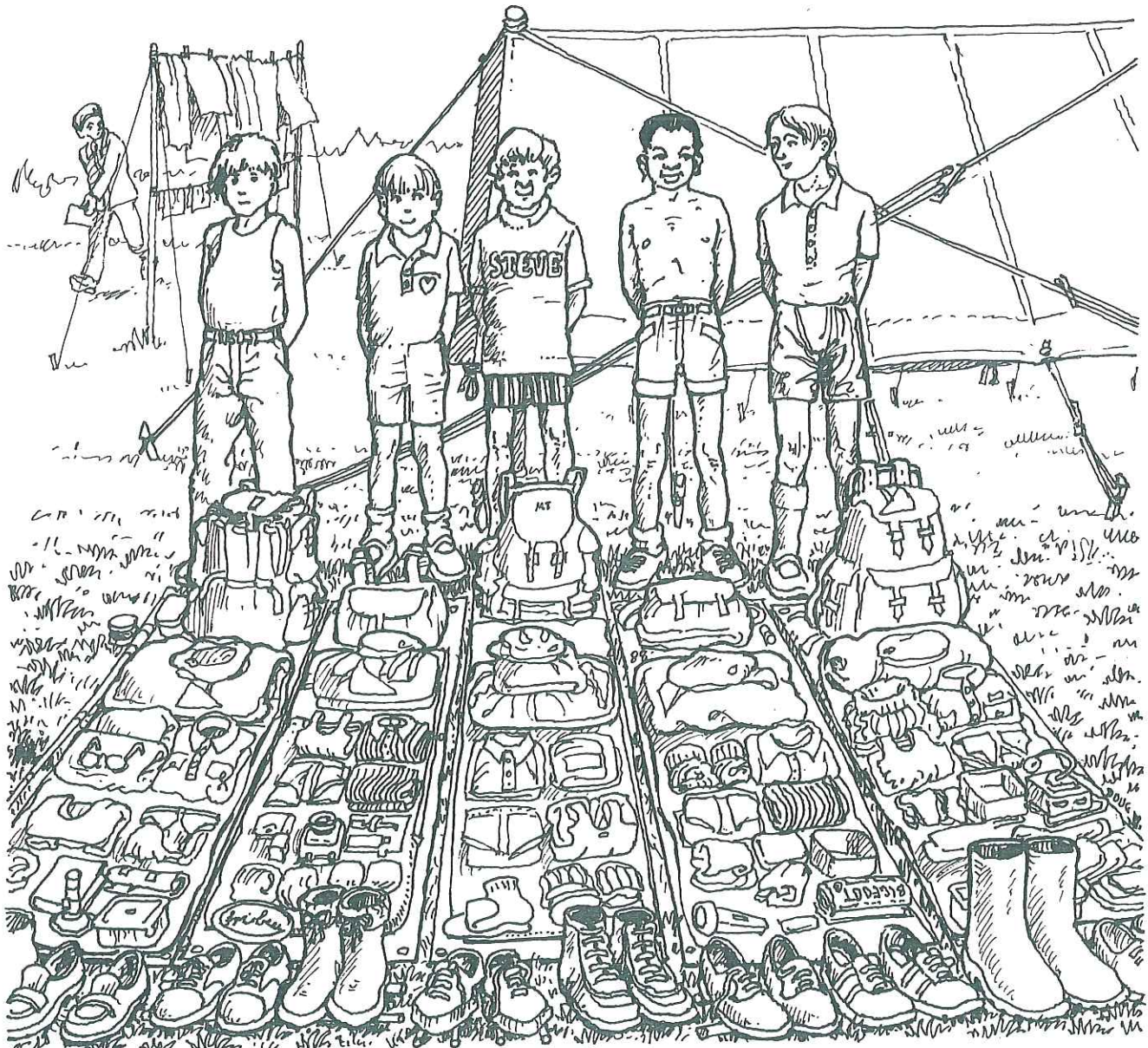

Points to remember:

- Nothing should be left in any bags, boxes, suitcases or, indeed, in the tent.
- All clothing, neatly folded, should be laid out on the sleeping bag as though a person were wearing it *i.e.* headgear on the pillow at the top, vests and shirts at chest level and so on. Footwear should *not* be on the sleeping bag but immediately at the foot.
- Damp towels and face-flannels should be hanging on the line to dry.

Written by Peter Brooks
Illustrated by Doug Mountford

Back - to - basics

Basic . . . flag poles

It is strange, but most Scouts don't feel their camp site is complete until they have a Union Flag strung aloft and fluttering merrily in the breeze! Whether upon a tree or a purpose-built flagpole is immaterial, the fact remains that the camp only becomes 'home' when the Red, White and Blue is flying.

But if there isn't a convenient tree around, it becomes necessary to build your flagpole. The ones shown below are the most commonly used designs and are probably most effective because of their simplicity.

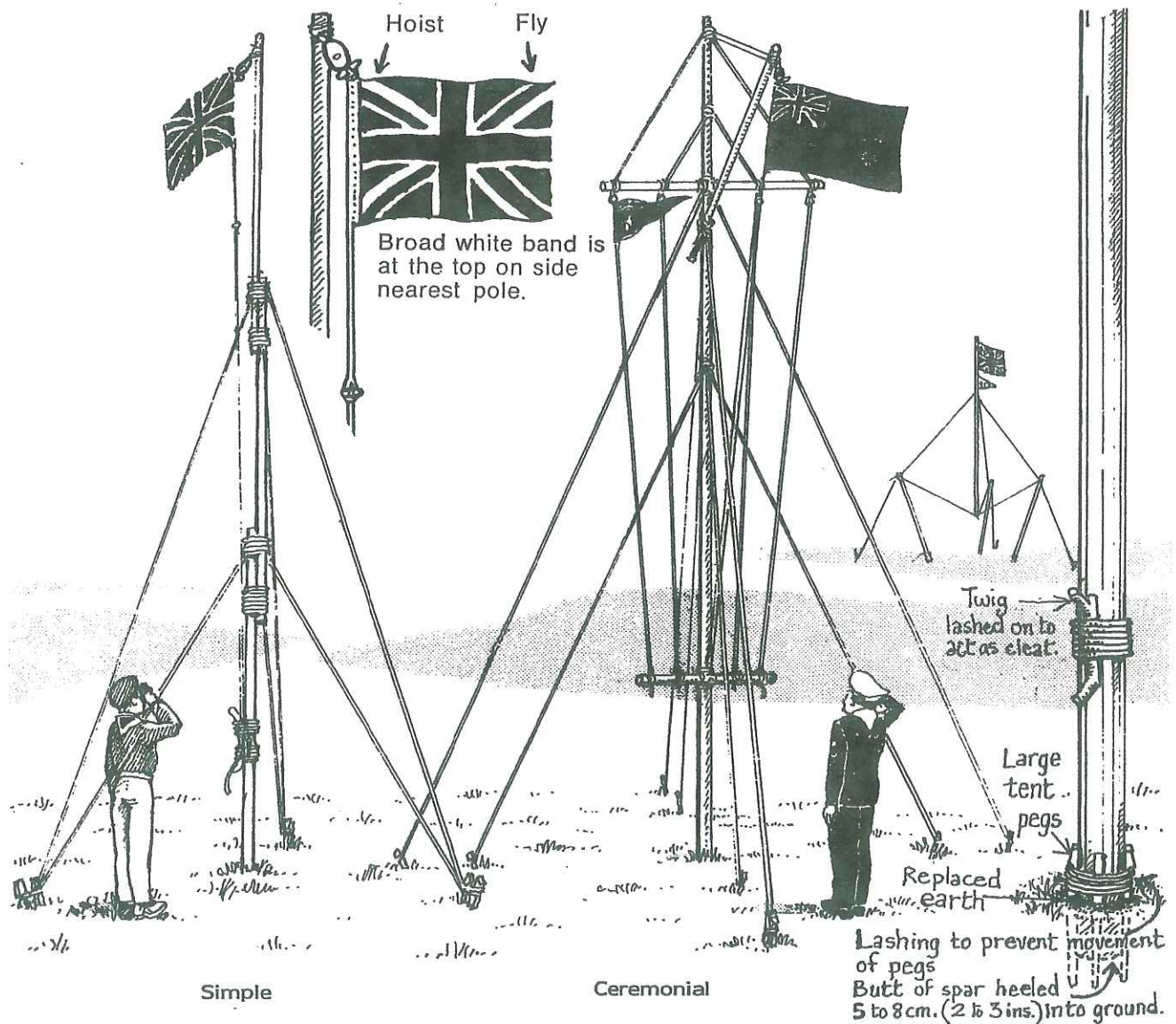

Points to remember

- Whether you use Scout staves, large bamboo canes or full-size pioneering spars, *it is imperative* that *all* your lashings are tight. A large flag in a stiff breeze will set up a terrific strain on both the pole and its lashings and you must ensure that your ropework is more than equal to it.
- Likewise, your flagpole must be adequately guyed — the bigger the flag and the taller the pole, the more sets of guys you will need.
- If you do use pioneering spars, remember to both heel the butt (that is, sink the bottom few inches of it in a hole in the ground then tightly repack the earth around it) *and* peg and lash it.

Written by Peter Brooks

Illustrated by Don M. ...

Back - to - basics

Basic . . . flag practice I

Every day of the week, literally hundreds of Troop Meetings (and many Pack and Unit Meetings, too) are opened with a formal little ceremony involving the United Kingdom's national flag, namely, the Union Flag (note, it is commonly mis-referred to as the Union 'Jack'. To be correct it is only a Union Jack when flown on a ship's Jack staff and on *all* other occasions it is the *Union Flag*).

Flag-break

While forming just part of the opening ceremony, the ritual of flag-break usually follows the following pattern or is something fairly close to this:

Before the Meeting — The flag is folded ready for breaking and is hoisted into position. This, in the Scout Troop, is usually done by the Duty Patrol Leader (if such a system is operated).

The ceremony — The Scout Leader brings the whole Troop to the 'alert'. The Duty Patrol Leader walks, or in some Troops marches, smartly to the flagstaff and, grasping the 'loose' halyard, breaks the flag with a smart tug. If the flag fails to break properly he 'helps' it, lowering it completely if necessary and breaking it manually. When satisfied he then takes two paces backwards and salutes the flag. This is the signal for the rest of the Troop to salute also. All return to the 'alert' and the flag-breaker resumes his position.

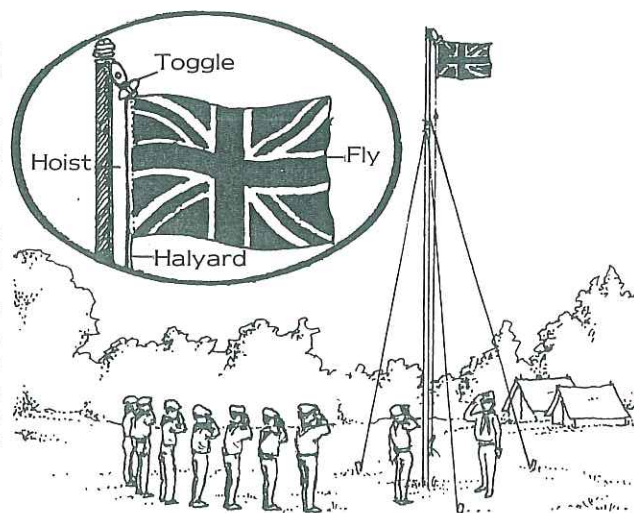

Folding the flag

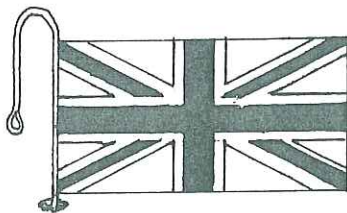
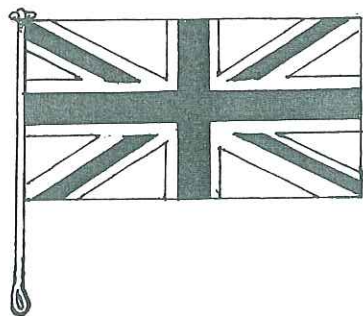

Hold or lay flag flat
(but *never* on the floor)

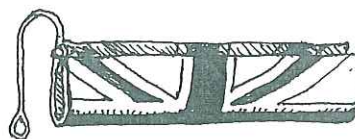

Fold in half lengthwise

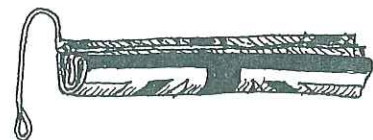

Fold in half lengthwise, again.
Ensure rope-tail is towards
outside

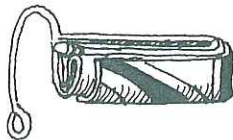

Bring two ends
together

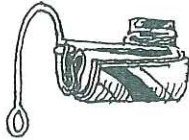

Concertina-fold
from fold towards
'hoist'



Wind rope-tail around bundle
(two circuits makes it more secure)
and tuck through itself

Attach flag to mast halyard (toggle through eye splice of halyard and sheetbend rope-tail to other end of halyard) and hoist with toggle to top. Secure this portion of halyard to cleat. Break flag with sharp tug on halyard secured to flag's rope-tail.

Remember:

- The Union Flag should not be allowed to touch the ground or the floor if possible. There is no specific ruling on this point but many people regard it as being disrespectful to the flag and thus to the country and HM The Queen.
- If flown upside-down, the Union Flag is a signal of distress.

Written by Peter Brooks
Illustrated by Doug Mountford

Back - to - basics

Basic . . . flag practice II

Most, if not all, Scout Groups possess colours and while there are not many occasions nowadays when they are paraded in public, there is no reason why we should forget how to do it properly. Attention to detail and smartly turned-out flag carriers who know what they are doing can only reflect well upon the Movement. Proficiency in this area will not add to the 'too militaristic' jibe of some, it demonstrates, on the contrary, a national respect and pride.

Flag carrying — on the march

Slope: Sloped over right shoulder, flag gathered in right hand, left arm swinging free.

Carry — gathered in: Pole vertical, flag gathered in and held in right hand, back of hand to front, level with mouth, elbow square and level with hand, left arm swinging free.

Carry — flying free: Position of hand as *Carry* but flag not gathered in.

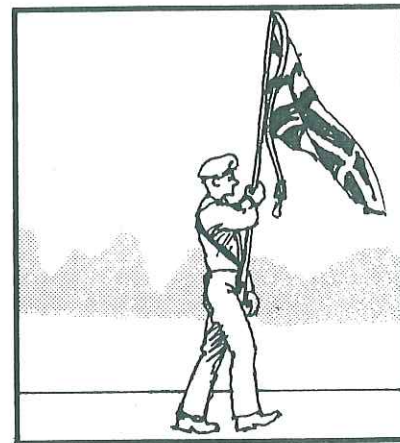
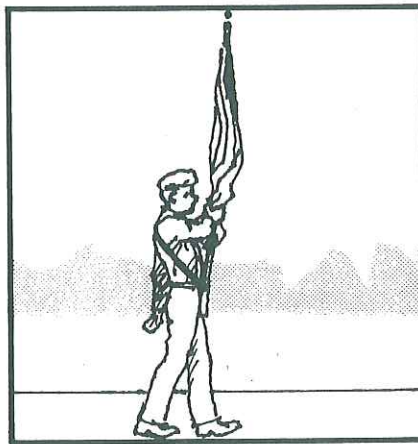
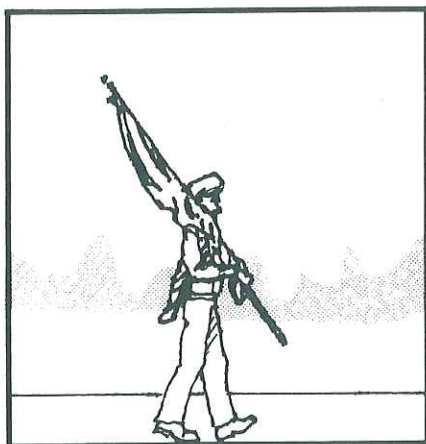

Use: The *Slope* is the normal method. The *Carry — gathered in* is used when marching. The *Carry — flying free* is the salute at the actual moment of passing the saluting base. **Note:** Both *Carry* attitudes are tiring and should be used sparingly.

At the halt

Order: Flag held vertically at the right side, butt on ground, gathered in right hand.

Carry — gathered in and Carry — flying free: As on the march but left arm to side.

Lower: Point of pole on ground, pole under right arm and flag free except when ground is wet or muddy.

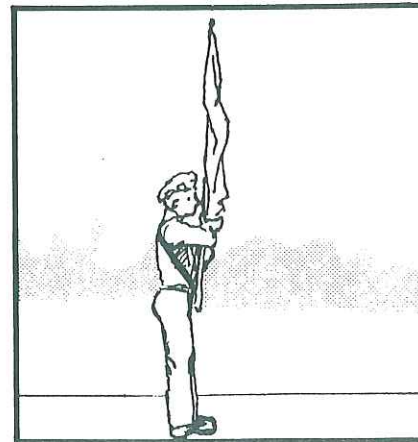
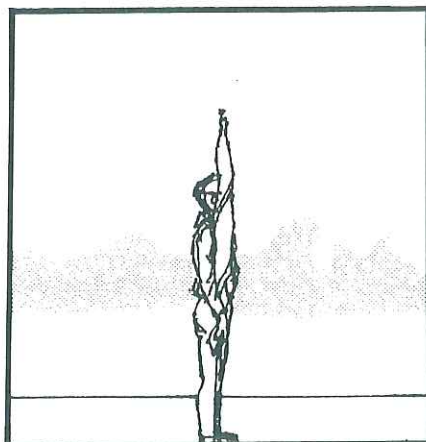

Use: The *Order* is the normal position. The *Carry — gathered in* and *Carry — flying free* are used on special occasions, such as an inspection.

Note: When parading with other bodies/organisations use common sense in departing from these rules. At international parades, it is normal custom to follow the practice of the host nation.

Written by Peter Brooks
Illustrated by Doug Mountford

Back - to - basics

Basic... axe safety

The use of an axe — how to stand, how to make the cut and so on — is something that can *only* be taught correctly and successfully person-to-person. It is *not* something that can, adequately or safely, be covered in a magazine or even in a book.

It is possible, however, to cover the necessary safety precautions and 'axe lore' that should be observed whenever an axe is about to be unmasked...



When you hand someone an axe, pass it head first, but support the head with your free hand.



Push down on haft to release

□ Always wear boots when using an axe — even a blunt axe will go through a plimsoll (and your foot!) like a hot knife through butter!

□ The chopping area should *always* be fenced off to a sensible height — *not* at trip-wire level.

□ Keep all spectators at *least* two axe-lengths away.

□ Remove any loose, sloppy or baggy clothing that might get in the way and cause an accident.

□ When masking an axe in a block of wood, make sure that no part of the axe overhangs the edges of the block and that the whole of the cutting edge is masked. To release the axe, simply push down on the end of the haft (handle).

□ Never chop where there are any overhanging branches, a washing line, nearby guylines or similar which could impede your swing.

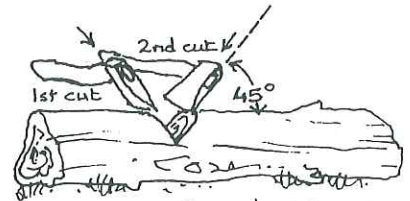

Cut from left and right alternately, at a 45° angle.



Make sure there are no overhead obstructions you could possibly touch with your axe.

An old groundsheet underneath the chopping block will catch the chippings and make clearing the site much easier.

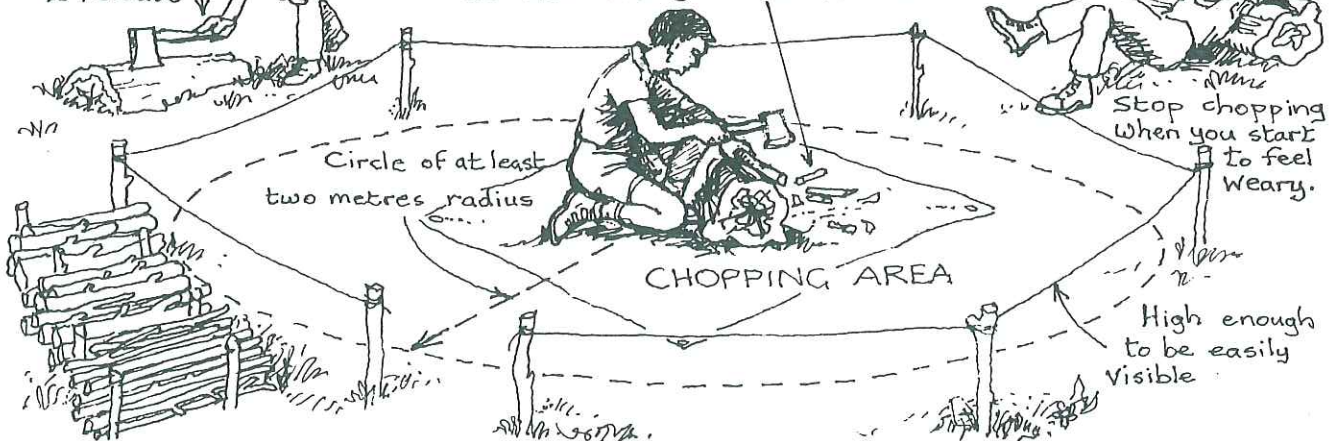

NEVER chop when you are tired as this is when accidents are more likely to happen — as soon as you start feeling weary, stop! You can always carry on again after a rest.

Perhaps most importantly, **THINK** about what you are doing all the time.

Written by Peter Brooks
Illustrated by Doug Mountford

Back - to - basics

Basic... food estimating

'An army,' it is said, 'marches on its stomach,' and although this creates a slightly ludicrous mental picture (well, it does in my mind, anyway!), we all know what it means. But if this is true for an army, it is even more true for a bunch of healthy young Scouts and particularly so if they are at camp or on an expedition and thus out in the open air, burning up even more energy than they normally do.

Feeding the brutes is a very important and responsible task but, especially for the newer Leader or inexperienced Patrol Leader, knowing how much food he will need to take to satisfy his charges is by no means easy or obvious.

Undoubtedly, practice makes perfect and after several years' camps, most Leaders can be expected to get it right — but that's not good enough because in the mean time, people will either be hungry (and in this condition, cold and misery are never far behind) or you will be buying too much food and wasting both it and the money that it cost.

The following list of foods and their quantities are the result of many years of experience and should, hopefully, short-circuit the above conundrum.

- Bread — Allow 1 loaf per day for 6 persons
- Bacon — 2 rashers per head per meal
- Baked beans — 60g (2oz) per head
- Butter/margarine — 60g (2oz) per head per day
- Cereal — 15-18 servings per 750g box
- Coffee — instant — 60g (2oz) per gallon (18 cups)
- Cheese — 8-10 salad servings per 500g (16oz)
- Gravy — 8 servings from 1 pint
- Milk — $\frac{2}{3}$ pt per head per day
- Minced beef — 150-180g (5-6oz), raw, per portion
- Porridge oats — 45g (1½oz), dry, per portion
- Potatoes — 250g (8oz), unpeeled, per portion
- Rice (savoury) — 45-60g (1½-2oz), uncooked, per portion
- Sausages — large — 3-4 per head (as a dinner)
- Sausages — small — 4 per head (as part of breakfast)
- Soup — $\frac{1}{2}$ pt per head
- Stewing meat — 150-180g (5-6oz), raw, per portion
- Suet pudding — 3 to 4 servings from a 500g (1lb) pudding (and *pro rata*)
- Sugar — 60g (2oz) per head per day
- Tea — loose — 30g (1oz) will make 20 cups
- Tea — bags — 2 cups
- Vegetables — 120-180g (4-6oz) per portion (depending on how many veg. you are serving)



N.B. Many of the above will need to be 'rounded-up' to full packets or tins per Patrol for ease of catering (particularly when Patrol cooking) but this extravagance will seldom be wasted!

The above was compiled with the help of Neil G Brooks, Eddie Greenhalgh, Bill Marshall and Dave Jordan, to whom we extend our thanks.

Written by Peter Brooks
Illustrated by Doug Mountford

Back - to - basics

Basic . . . steps to camp

Any very new and inexperienced Scouter can be forgiven for quailing slightly at the thought of taking his charges away to camp for the first time. It is, after all, not an easy task.

Probably the most daunting part is the planning as there are so many things to remember and set in motion at the right place in the schedule of events leading up to the great day. But, like so many other things, once one has a starting guide — within reason, however rudimentary — one's task becomes that much easier and some of the inherent 'bogies' at least begin to fade, if not disappear altogether.

Set out here is just such a guide to help you over those first few hurdles. With time and practice you won't need this 'supporting hand', your growing experience and confidence will enable you to embellish some areas, simplify others and take the odd short-cut or two (but *never* at the expense of safety, please!).

■ Where?

This very much depends on the sort of site you are looking for — do you want the sea, hills, a river, open space? Consider the likely transport costs as well, when deciding on the area to visit.

■ Finding the site

The National, County and District Camp Sites Booklet (available from the Resource Centre at Gilwell Park) will help. There are camp site advertisements in SCOUTING Magazine, too. Speak with other Leaders in your District who have been to or know the area. Many County Secretaries supply a list of sites in their Counties upon request — your District Commissioner will be able to get you the address. He or she will also advise you of any prohibited area where you may not camp.

■ Visit

If at all possible, visit the site with your Patrol Leaders before making a decision.

■ Travel

The most likely alternatives are: train, coach, minibus, car or cycle or a combination of any or all of them. Investigate the costs and 'flexibility' (will the schedules of the first two tie-in with your plans) of all feasible alternatives before making a decision.

■ Cost

Estimate the number of campers and the cost of food, transport, site fees, expeditions, extra equipment needed and add a percentage for 'contingencies'. Divide this total by the expected number of campers.

■ Form PC

If your camp is to be of five nights duration or longer, complete *Form PC* for permission to camp and send it via your Group Scout Leader to your District Commissioner. This must be done at least two months before the date of departure. If you will be camping for less than five nights you do not need this form but Cub Camps and Pack Holidays need to complete one *whatever their duration*.

■ Provisionally book site and transport

■ Letter to parents

Include details of dates, venue and an estimated cost. Include a 'My son would like to come . . .' slip and ask for a nominal deposit to secure a place.

■ Open camp bank

Particularly useful for summer camp fees which can then be paid off by parents in instalments or *en bloc* as desired, camp banks are often used to 'hold' pocket money, on demand, so that boys do not have large amounts of cash to carry around.

■ Programme

Discuss programme activities with the Patrol Leaders' Council. This could suggest some training requirements to be carried out before camp.

■ Menu

Work out the menu, bearing in mind your programmed activities, and decide quantities.

■ Parents' permission to camp

Decide actual cost per head on numbers now attending. Complete *Parents' Permission to Camp Forms* (available from Scout Shops Limited), with departure and return dates and times, kit list and so on, and circulate to parents for signature and return.

■ Equipment

Prepare list of equipment needed. Arrange with Patrol Leaders for checking and packing it.

■ Pre-orders

Send off any orders for milk and bread (often available from local suppliers via the site warden). Food can often be ordered in advance from local grocery stores, too.

■ The night before

If you have an early start in the morning arrange for the Scouts to bring their kit to your Headquarters the night before. Give final briefing. Try to get a good night's sleep!

■ You're off! Have a good time!

Back - to - basics

Basic . . . steps to camping abroad

In an earlier *Back-to-basics* we looked at the steps to be taken with regard to taking the Troop away to camp.

But suppose you want to be that little bit more ambitious . . . Suppose you want to take them *abroad* for next year's summer camp . . . What *extra* arrangements — over and above the usual crop that we listed in the earlier piece — have to be made, who has to be told, what extra forms have to be filled in and so on?

The following should, we hope, be of use although it should be stressed that this is not an absolutely definitive list — each overseas expedition will throw up its own bunch of 'funnies' with which you will have to cope but, that said, let's look at what you have to do and consider. . .

E111 — If you will be visiting a European country, *most* of them have reciprocal health arrangements with the United Kingdom so that any treatment that you may need is paid for by the National Health Service. The leaflet *Before You Go: The Traveller's Guide to Health (Ref: SA40)* is available from your local Department of Social Security Office and tells you how to apply for a *Form E111* for each member of your party.

Passports/visas — Some youngsters will already hold their own passports but Visitors Passports — valid for 12 months — can be obtained from Main Post Offices but beware, though, as not all countries accept them. The Post Office is also the place to collect an application form for a full British Passport (but remember to apply in good time as processing of applications, particularly immediately prior to the main holiday season, can often take several months). Another alternative worthy of consideration is to obtain a Collective Passport to cover between five and 50 youngsters under the age of eighteen.



For many countries outside Europe you will need a visa before entry will be granted. Check with your travel agent or the appropriate embassy.

Vaccinations/innoculations — Consult your own doctor then issue guidance to the rest of the party.

Money — Foreign currency is obtainable from any bank (most will need a week's notice) and from larger travel agents.

Money can, however, be a problem as you might have to carry the whole lot with you (if you are visiting a remote area) or take it in the form of travellers cheques (although this can lay one open to fiscal mismanagement charges as travellers cheques are drawn and cashed against a single signature).

Useful phrases — Suggest a list of useful phrases that all the party should learn *and use* — although many people overseas do understand/speak English, it is a courtesy that many will appreciate if they are addressed in their own language.

International driving licences — If you are taking a vehicle with you, both it and you will need the necessary paperwork. You may need an International Driving Licence if you are going outside Europe and an insurance green card. Consult one of the major driving organisations who will be able to advise on any particular paperwork you will need for your journey. Minibuses must comply with European Community regulations for tachographs, documentation and so on.

Maps/information — A visit or telephone call to the Tourist Office of your destination, will bring forth fistfuls of helpful information, brochures, pamphlets and, in many cases, maps too.

Insurance — Extra insurance cover *will* be needed to cover accidents, injuries, delays, baggage and money, loss of equipment, cancellation/curtailment and repatriation and the 101 other 'bugs' that can arise to ruin an expedition. Scout Insurance Services, at Lancing, have a competitively priced policy, tailor-made to suit Scout needs.

Union Flag badges — Available from Scout Shops Limited, these badges can be worn on uniform for one month before and up to 12 months after an expedition abroad.

International Department at Headquarters — Much useful information regarding just about every aspect of a trip abroad can be obtained from the International Department at Baden-Powell House. Additionally, early contact with your Assistant County/Area Commissioner (International) will prove very helpful and probably save you much wasted effort (as you will be able to use experience gained by others in previous expeditions).

Form PC (Abroad) — As soon as you can, complete a *Form PC (Abroad)* and return it to your Assistant County/Area Commissioner (International). This will then be forwarded, via the International Department, to the Headquarters of your destination country so that they will know you are visiting.

International Letter of Introduction — This is sometimes known as 'The Scout Passport', for, although it carries no weight in the 'passport' sense, it establishes you and your party as *bona fide* Members of the Movement and helps to ensure you a warm welcome from Scouts in other countries. It can be obtained from the International Department at Baden-Powell House.

Written by Peter Brooks
Illustrated by Doug Mountford

Back - to - basics

Basic... map reading I

It is widely acknowledged that the United Kingdom is covered by the best set of maps in the world. The accuracy, detail and quality of the maps produced by the Ordnance Survey is unparalleled and is, indeed, envied around the globe.

Although these maps are produced in a number of different scales (with consequent differences in the amount of detail they show) the one most used by Scouts and Venture Scouts is probably the Landranger Series. This is drawn to a 1:50 000 scale which means that 1 centimetre on the map represents 50 000 centimetres (or half a kilometre to put it another way) on the ground, so 2 centimetres equal 1 kilometre and so on — a little practise and this sort of conversion will become automatic.

Even a casual glance at any Landranger Series map will reveal an almost bewildering array of different coloured lines and little pictorial symbols, many of which are self explanatory while the remainder can be found by referring to the 'Key' printed on the side of each map. Once again, considerable practise at reading a map will be necessary before you fully appreciate the tremendous amount of detail it contains.

You will also find that the whole map is covered with a grid of thin blue lines, those running vertically are called *eastings* and those running horizontally are called *northings*. Each line is numbered between 00 and 99 and as, obviously, there are more than 100 lines across the United Kingdom these numbers are repeated. The squares formed by these 100-line by 100-line segments are then designated by a 2-letter code. The use of this code and a 6-figure *grid reference* (which we will deal with below) enables you to pin-point any location in the country.

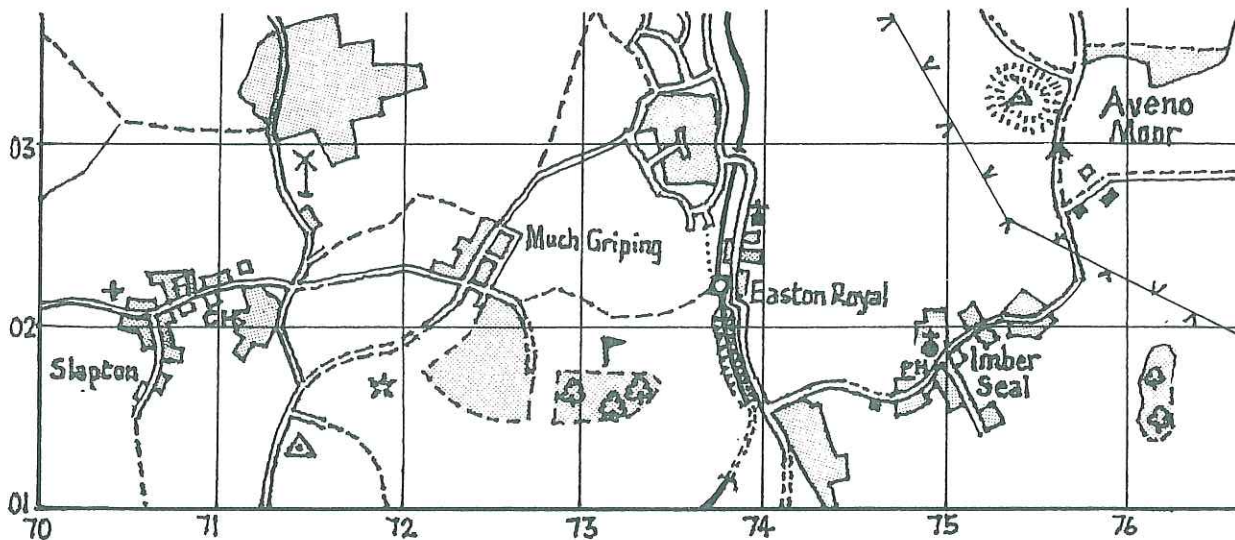

Reading a grid reference

Let's assume we wish to find the grid reference of the railway station in the village of Easton Royal.

Step one: Read, from the top or bottom edges of the map, the number of the vertical easting line on the lefthand-side of the station. In our illustration it is 73.

Step two: In your mind, divide that square into vertical tenths and decide how many tenths from that easting the station is. It is approximately 8.

Therefore the easting reference is 738. Whether reading or quoting a grid reference, the first 3 numbers *always* relate to the easting.

Step three: Now, working in a similar fashion, read the number of the nearest northing (horizontal) line below the station. This gives us 02.

Step four: Again, in your mind, divide the square horizontally into tenths and decide how many tenths the station is above the 02 line. It is roughly 2.

Consequently the northing reference is 022.

Therefore, the 6-figure grid reference for the station at Easton Royal is 738022. (If the letter-code is omitted this reference will recur every 100 kilometres across the length and breadth of the country but as even the most inexperienced beginner is unlikely to be 100 kilometres from where he expects it to be, it is seldom used!)

A simple mnemonic to help you remember which set of numbers to read first is 'In the door... and up the stairs', so, starting at the bottom left corner, you come in and along the bottom first to read the easting, then go up the map to locate the northing.

Written by Peter Brooks
Illustrated by Doug Mountford

Back - to - basics

Basic . . . map reading — II

As anybody who has ever ridden a bicycle will be more than aware, Britain is not a flat country — far from it! Obviously, there are bits that are flat but, generally, the United Kingdom is noted for its rolling hills, its picturesque valleys and its imposing landscape. Among all the other information contained on Ordnance Survey maps is a series of orange-brown lines which convey the pattern of these hills — they are known as 'contour lines' and they link together places of equal height above sea level.

Drawn at the equivalent of ten-metre intervals (with every fifth line being slightly bolder to aid identification) they can be 'read' to give you a picture in your mind of what the actual terrain is like.

Lines drawn close together indicate that the land rises or falls (i.e. gains or loses height) rapidly, while contours spaced more widely apart show that the slope, either up or down, is more gentle. Each contour will have its height above sea level printed on it at intervals so it is easy to decide if the ground is rising or falling. Shown below are some of the more common land formations and their equivalents in contour lines:

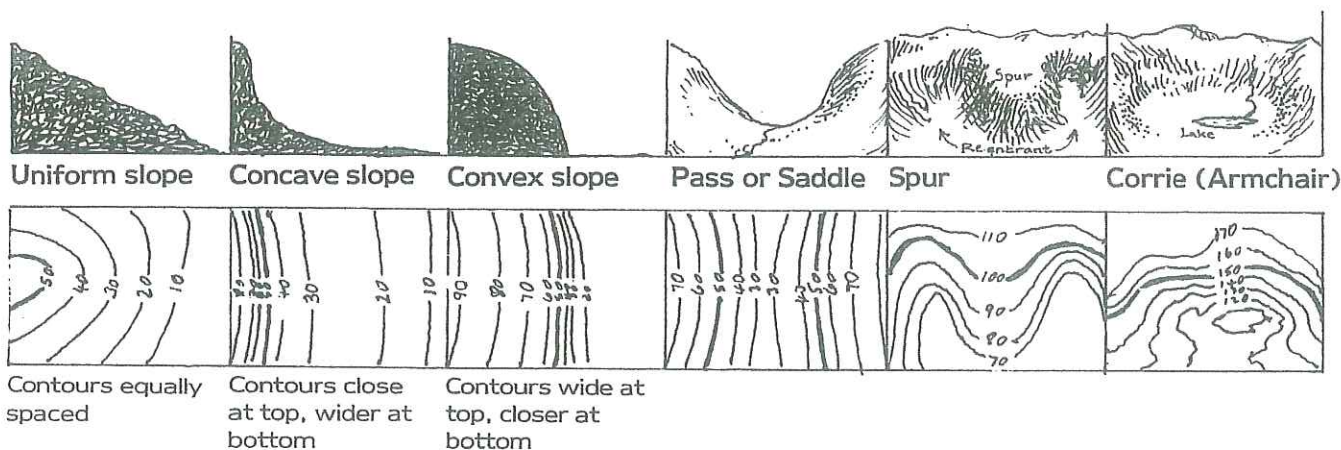

The following simple exercise will help you discover the shape of a hill or part of the route you wish to follow.

Contours of hill reproduced from the map

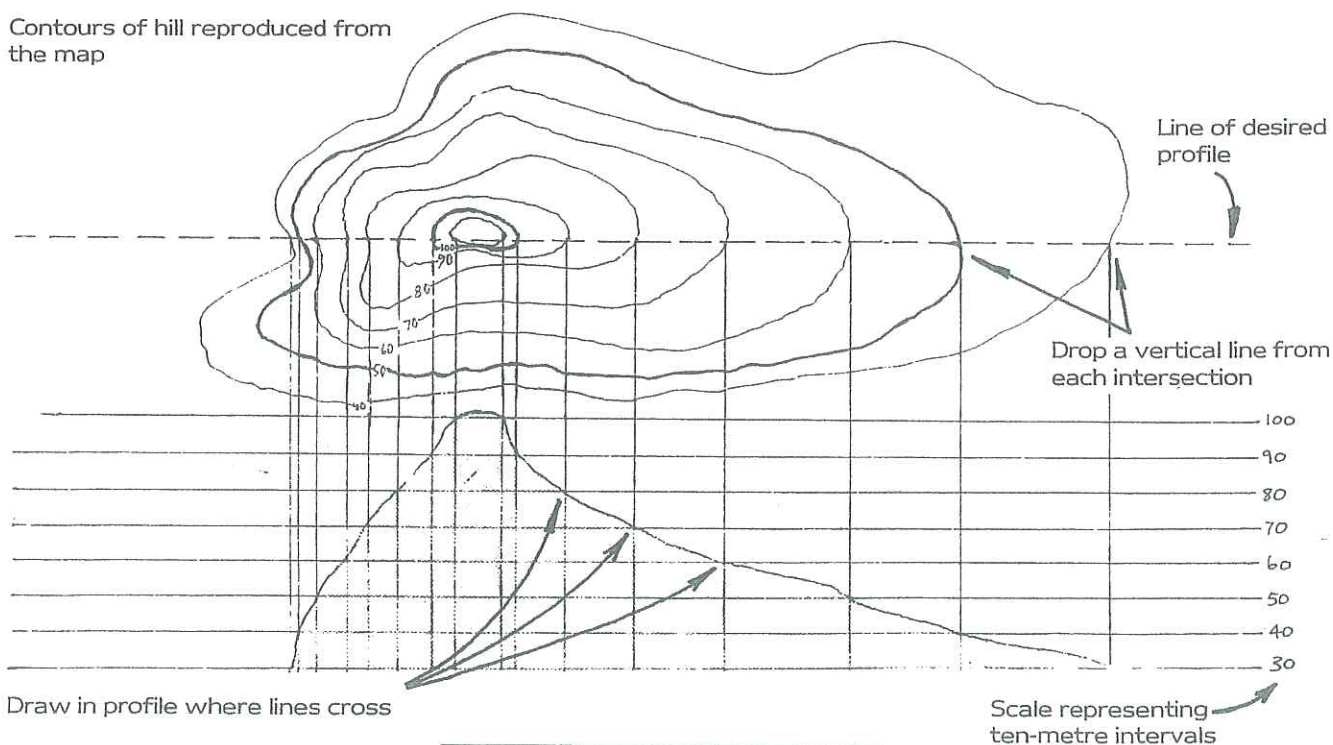

Written by Peter Brooks
Illustrated by Doug Mountford

Back - to - basics

Basic... map reading — III

Even an absolute 'thicko' knows that compasses point to North. The fact that there are *three* Norths — Grid, Magnetic and True — is not such common knowledge but knowing which is which, how to find them and how to be guided by them is another of the rudimentary skills which all Scouts should possess.

Compasses have varied in pattern greatly over the years but the one most commonly used by Scouts nowadays is the Silva-type compass illustrated below. While one can learn the names of its various parts from this diagram, there is no substitute for actually holding one in your hands and practising with it.

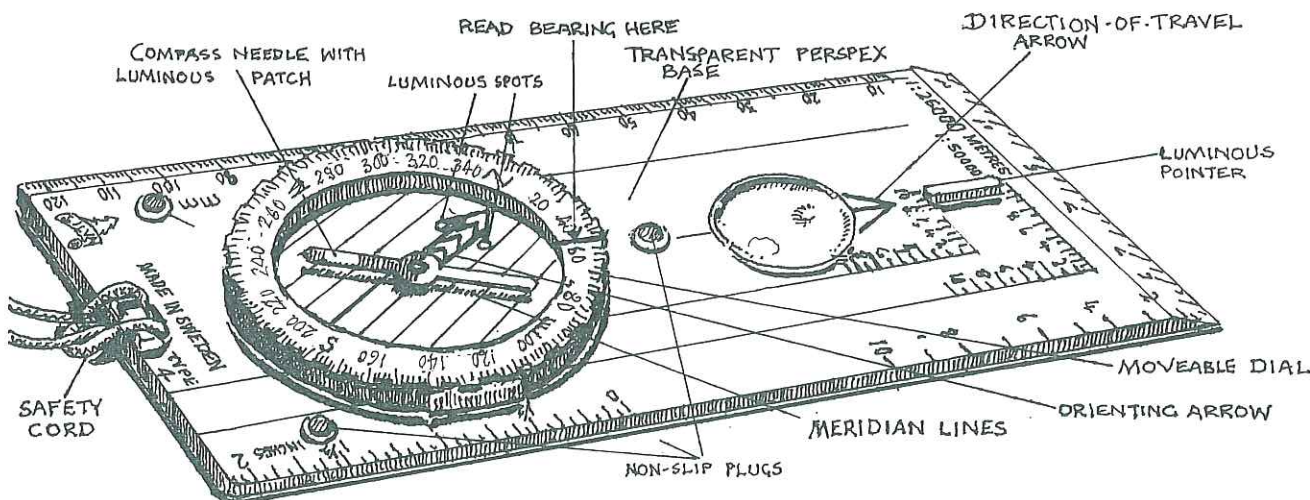

Setting your map

Likewise, while we can describe here how to set your map, it is far better (and you will find it far easier) if you have a compass and map here, with you, as you read, so that you can translate these words into *doing* immediately. In this way you are far more likely to remember what to do but, as always, the secret is practise, practise and practise again!

Look up the magnetic variation on the map's Orientation panel — it is usually about 6° (but it is gradually changing so remember to check regularly and, in fact, it varies, from side to side and from top to bottom on each and every map) — and set your compass to this bearing (where it says 'Read bearing here' on the illustration). Now, line the compass needle and the orienting arrow (on the base-housing), making sure they are the right way round. Your compass now points to Grid North. If you now line the vertical grid lines on your map with the long edge of the compass, your map will be set to Grid North.

You can also set your map using two landmarks that are clearly visible and for which symbols will appear on the map (hills, windmills, lighthouses and so on). This method is quite simple but beware of similar-looking features which might be confused. Finding a third landmark is a good back-up check.

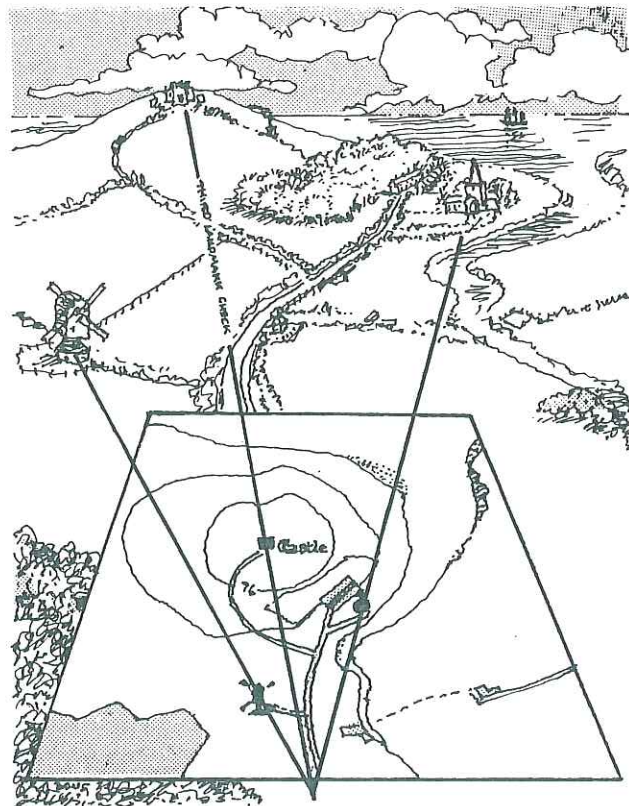

Written by Peter Brooks
Illustrated by Doug Mountford

Back - to - basics

Basic . . . map reading — IV

Having, in an earlier *Back-to-basics*, looked at a compass and how to set a map, we must now progress to the next stage and learn how to read bearings and walk on them. While this process is not complex, it must be stressed, yet again, that *practice* is the only way of becoming proficient in this skill — knowing the theory is no substitute for 'hands-on' experience in the field (or on the hill, in the forest, on the downs, moor or wherever!).

Finding a bearing

Having first set your map and worked out the route along which you wish to travel, place the edge of your compass base in the chosen direction. Rotate the dial until the orienting lines are parallel with the map's grid lines and the arrow on the dial is pointing to the top of the map (north).

Read off the bearing at the base centre-line (beneath calibrated dial) then, by rotating the dial *anti-clockwise*, add the magnetic variation (currently about 6° but this does vary with time and you should check the Orienting panel of your Ordnance Survey map from time to time). Once found, you can walk on this bearing without constant reference to your map.

Alternatively it is sometimes possible to take a bearing upon a landmark visible in the distance which, by good fortune, is in the direction in which you wish to walk. If you are even luckier, this landmark will be visible the whole time and you will be able to walk, unhampered, towards it.

If no landmark is visible in front of you, try looking backwards. If you find something suitable, take the bearing but instead of walking on that bearing *you walk along the reciprocal bearing* i.e. your bearing plus 180° .

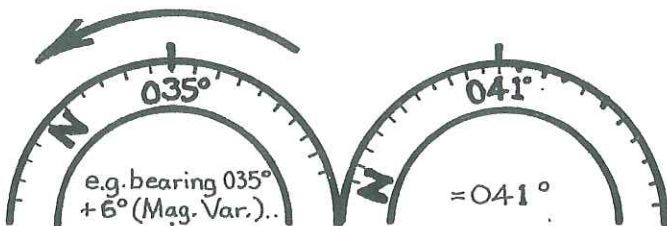
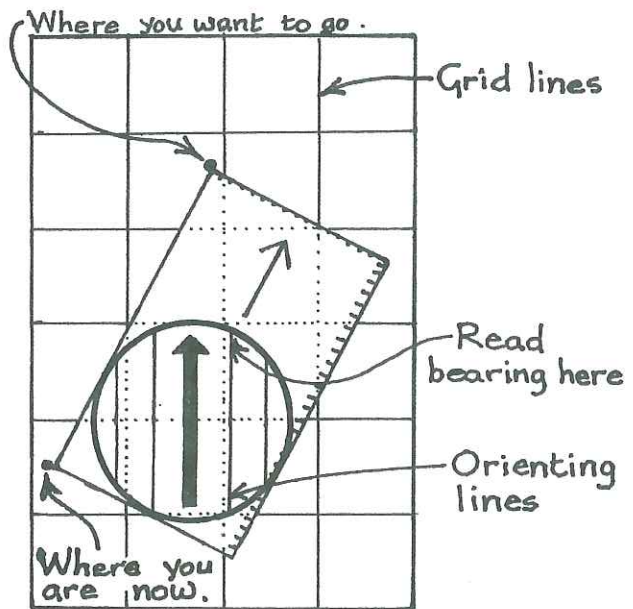

Deviating from course

Often, however, buildings, trees or other obstacles will get in the way of your chosen bearing route and you will need to deviate to circumvent the problem.

In this case you just turn 90° to right or left and walk, counting your steps, until you are clear of the obstacle. Again turn through 90° (i.e. parallel to your original direction) and walk until past the obstruction. For the third time, turn through 90° (back towards the original route) and walk the same number of counted steps then, finally, turn through 90° again and you will be back on course. Although this might be regarded as a slightly pedantic method of staying on a route, it does work, provided your counting, turns and so on are accurate.

Remember Accuracy is important in all compass and bearing work — an error of just two degrees will mean, over a journey of, say, just six kilometres, that you will miss your target by 200 metres and that could literally mean the difference between you living and you dying! Overdramatic? — Not really, imagine being lost on a fog-bound, snow-covered moor and imagine walking right past — without even knowing it — the only habitation for, perhaps, 20 miles in any direction . . .

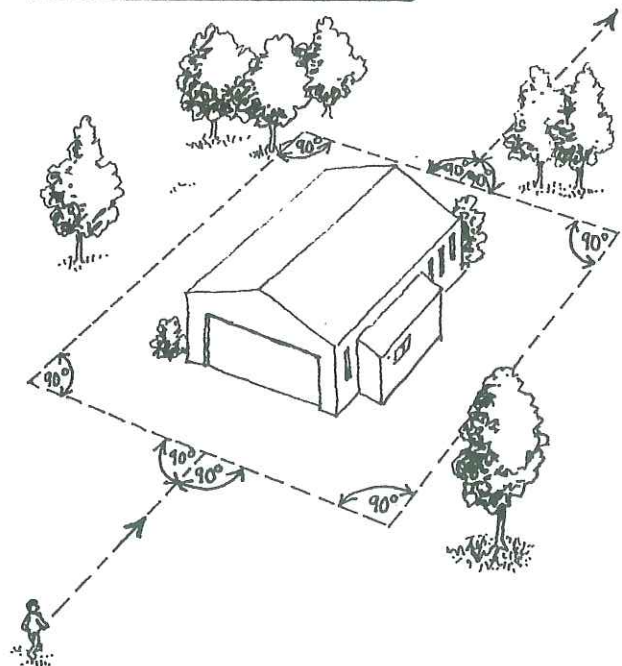

Written by Peter Brooks
Illustrated by Doug Mountford

Back - to - basics

Basic . . . ways of finding your bearings

Without doubt, the most obvious answer to the question 'How do you find north?' is simply 'Use a compass!'. While this is undeniably true, 'yer average Scouter' needs to be prepared for the occasion when he hasn't got a compass to hand and yet he still needs to be able to work out his bearings and thus know in which direction he should be walking.

But even if such a situation doesn't arise, it makes his tutoring of compass work that much more interesting to the lads if he can say 'There are, of course, other ways to work out your bearings without using a compass . . .'. Here, then, are a trio of those 'other' ways:

Using the sun and a watch with hands

- Point the *hour* hand of your watch at the sun.
- During *Greenwich Mean Time*, bisect the angle between '12' on your watchface and the hour hand.
- During *British Summer Time*, bisect the angle between '1' on your watchface and the hour hand.
- In both cases, the resulting line points north/south. True north is at the end furthest from the sun.

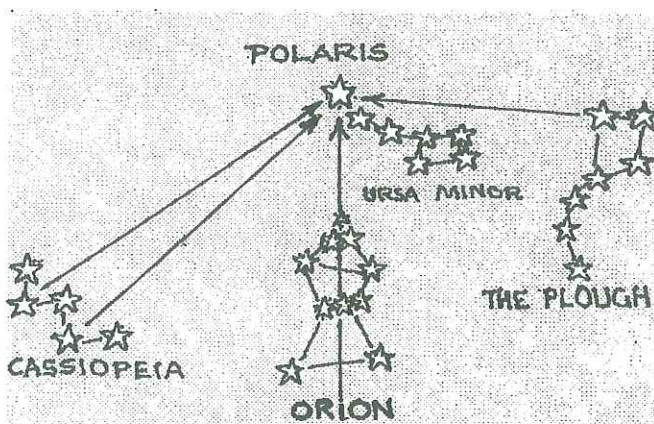
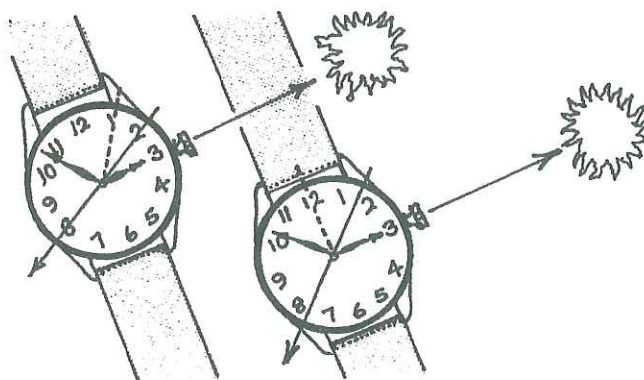

Using the stars

To find north at night you must first locate the Pole Star (and if it is a cloudy night and no stars are visible, you are in trouble!).

Polaris, as the North Star is more formally known, is situated over the earth's North Pole and once you have found it you will be able to estimate other directions from it.

Using shadows

This method also relies on sunlight or, if you are lucky and it is a bright night, upon *moonlight*, provided either is strong enough to cast shadows.

Drive a fairly straight stick into the ground, keeping it as vertical as possible (a weighted string as a makeshift plumbline will help). Mark the top of the shadow it casts with a pebble or twig. After, say, 15 minutes, again mark the shadow. A line from the first mark through the second will, in the northern hemisphere, point *roughly* east.

This method is surprisingly accurate during the middle of the day but varies slightly in early morning and late afternoon.

At any time it is only a fairly approximate way of direction-finding but it will get you out of trouble.

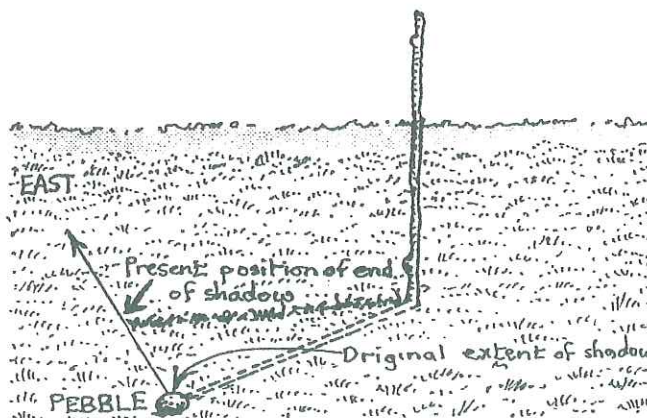

Written by Peter Brooks
Illustrated by Doug Mountford

Back - to - basics

Basic . . . knotting

Tying ropes together is easy! Knowing *what* knot to use in *which* circumstances is a little more difficult — but not much! There are, literally, thousands of knots, hitches and bends but, fortunately, Scouts only need to know a very small percentage of these (although, for some, knotting has developed into a life-long hobby), here are just a few that most Scouts will come across at some time or other.

Reef Knot

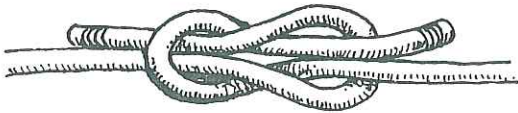

Clove Hitch

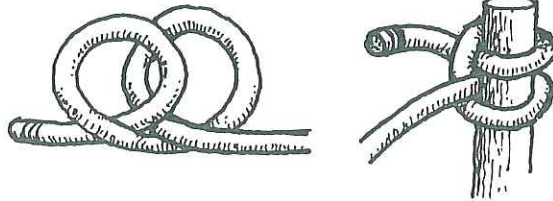

Sheet Bend (and Double Sheet Bend)

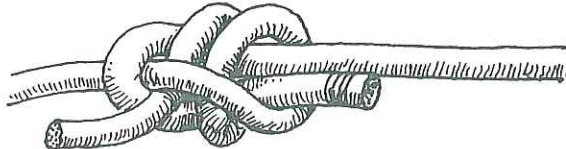
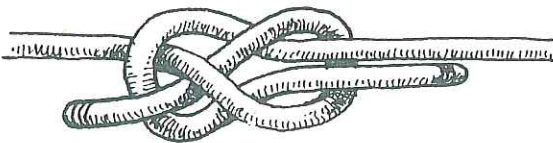

Bowline

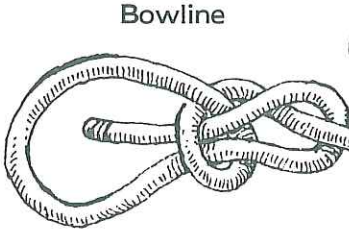

Sheepshank



Figure of Eight



Fisherman's Knot

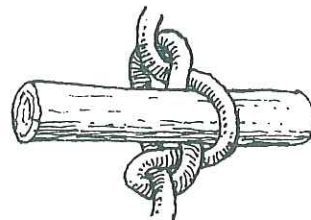
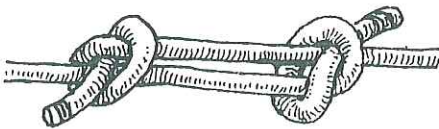

Marlinespike Hitch

Highwayman's Hitch

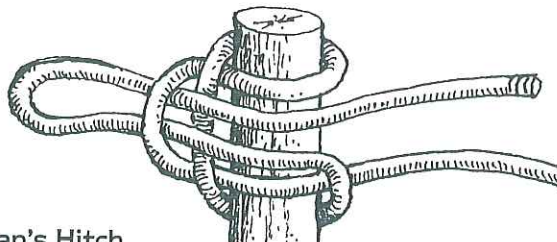

Remember there is absolutely no substitute for learning knots with a piece of rope — these pictures will help you but regular practice, until you can do them in the total dark and *know* they are correct, is the only answer.

Written by Peter Brooks
Illustrated by Doug Mountford

Back - to - basics

Basic . . . lashings I

You cannot get very far with any pioneering without coming across the need for a lashing. Indeed, there are very few structures that can be built without any at all.

It is very easy to do lashings — it is even easier to do them badly! The secret is to make them as tidy as possible and *as tight as possible*.

Square lashing — used to lash two spars together, whether they are at right-angles or not, when they are touching.

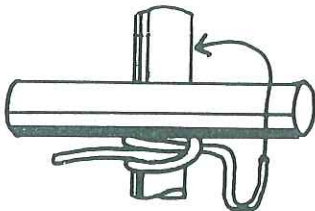

1. Start with a Clove Hitch.

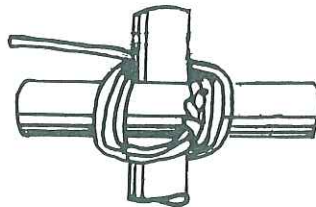

2. Over the first spar, under the next, over and under and so on.

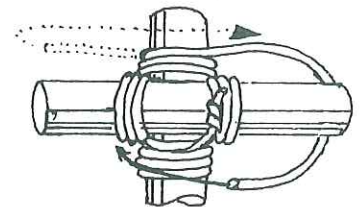

3. After three complete circuits, change to a horizontal direction.

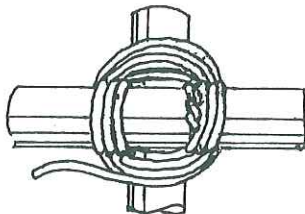

4. Add three frapping turns, these tighten the lashing.

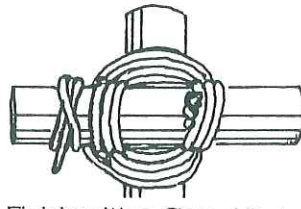

5. Finish with a Clove Hitch.

Sheer lashing — used to lash poles to form a longer length, perhaps for a flagpole.

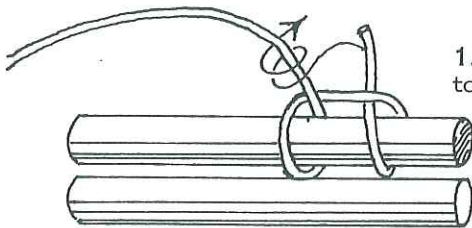
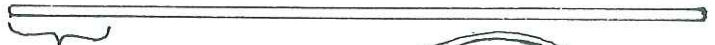

1. Overlap poles by 30 to 45cm (12 to 18in).

2. Start with a Clove Hitch.

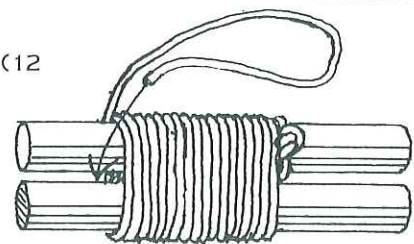

3. Wrap rope around both poles for 10 to 15cm (4 to 6in).

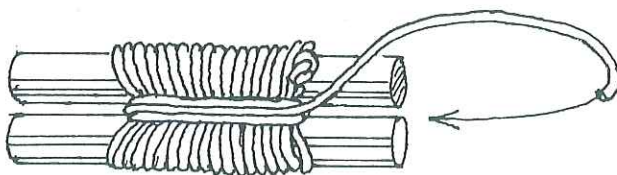

4. Add frapping turns to tighten lashing.



5. Finish with a Clove Hitch.

Adding a second Sheer Lashing will strengthen the overlap as, then, no movement is possible in any direction.

Written by Peter Brooks
Illustrated by Doug Mountford

Back - to - basics

Basic... lashings II

Because pioneering is virtually exclusive to Scouting (indeed, if asked, most members of the general public, unless they have been in the Scouts or Guides themselves at some time, wouldn't even have a clue what pioneering *is!*) it follows that the knowledge of how to make lashings correctly is also the Movement's almost exclusive preserve.

The feeling of one-upmanship that this affords does, however, carry with it the responsibility of making sure that these skills are passed on — correctly — to our young Members. It is then incumbent upon them to further communicate these skills on down the years as their turns come.

Diagonal lashing — used to lash, by drawing together, spars which cross but do not actually touch (yet!).

1. Commence with a Timber Hitch to draw the spars together.

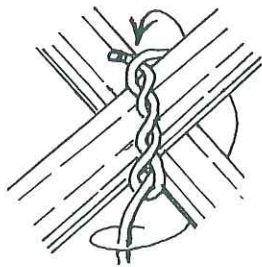

3. Change to horizontal plane and add three frapping turns, these further tighten the lashing.

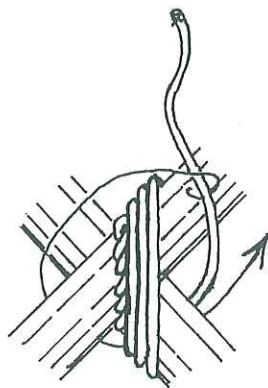

2. Make three *tight* complete circuits in the same direction, then change direction and make three complete circuits at right-angles to the first.

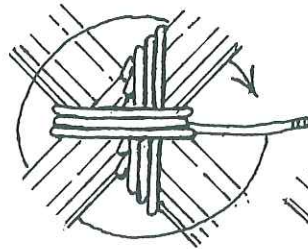

4. Finish with a Clove Hitch.

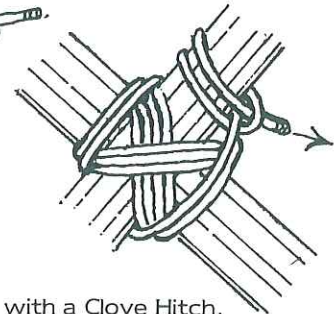

Japanese lashing — this is an alternative to, and slightly easier version of, the Square Lashing (see *Back to basics — lashings I*).

1. Middle the lashing under the bottom spar.

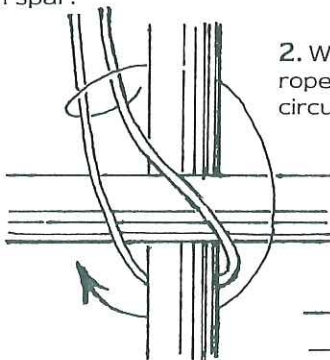

3. Split ropes and work as shown to change plane for frapping turns.

2. Work as shown, using the two ropes together, for two complete circuits.

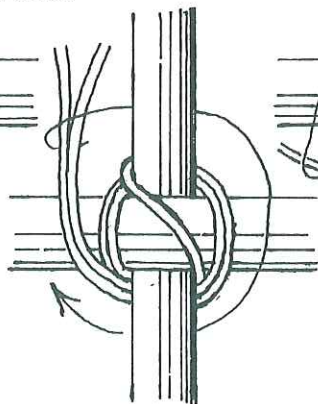

4. Finish with a Reef Knot.

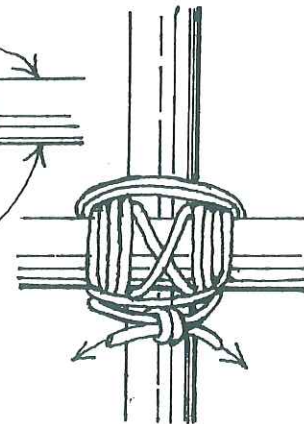
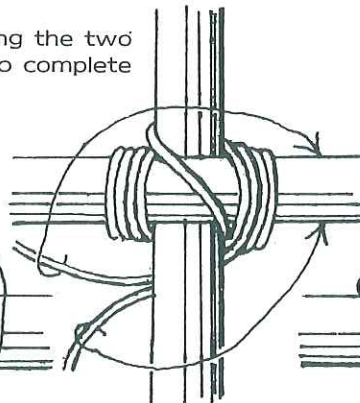

N.B. The principles of the Japanese Lashing can be applied to the Diagonal Lashing, too. Middle the rope and start as shown. As above, work with the double rope, single-up for the frapping turns and finish with a Reef Knot.

Written by Peter Brooks
Illustrated by Doug Mountford

Back - to - basics

Basic . . . splicing

Splicing is another of those skills which, if we are not careful, will, as John Sweet so aptly put it a month or two back, 'slip unnoticed down the cracks in the pavement of Life' and disappear forever. Whether that should be allowed, or, perhaps, even encouraged, is a debate we will not enter into here but suffice it to say that there are occasions for the use of splices, so we are perfectly justified in including just a couple of them here.

The back splice

The main drawback with the back splice is that it effectively doubles the thickness of the rope, which could prevent it being reeved (passed) through a block in pioneering. Known in the navy as 'the lazy man's whipping' it should only be used as a temporary rope-end in the absence of any whipping twine.

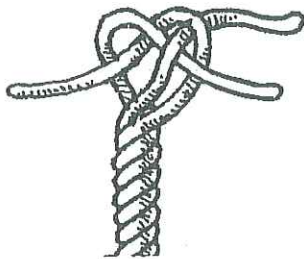

Unlay the rope for about six times the circumference and form a Crown Knot. Tighten down crown.

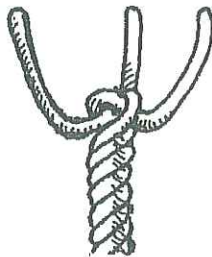

Working against the lay, pass each tail over strand next to it and under next one. Pull each back towards crown to keep splice tight.



Repeat over-one-under-one routine twice more (so three 'tucks' in all). Trim off tails and roll splice between hands to make a neat finish.



The finished back splice.

The eye splice

Used to form a permanent 'eye' in the end of a rope.

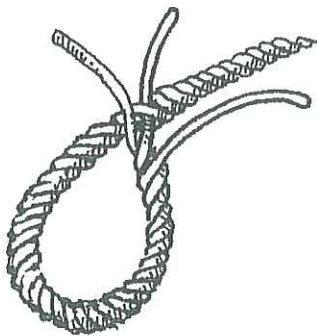

Unlay about 8 cm (3 in), form an eye of the required size and tuck the *middle* strand through the lay.

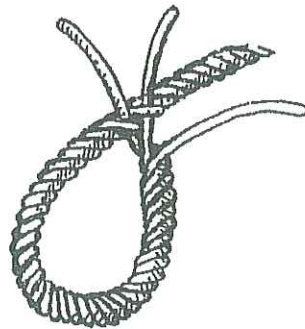

Tuck *left* strand through lay to left of first tuck.

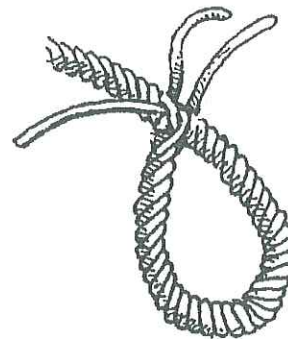

Turn rope over and tuck remaining strand through unoccupied lay.

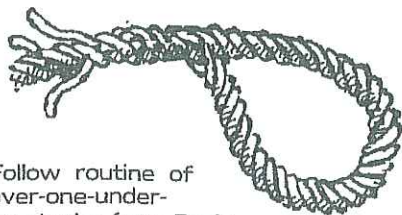

Follow routine of over-one-under-one tucks (see *Back splice* above) for two more circuits.

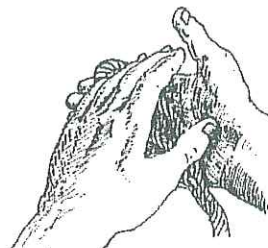

Trim off tails and roll splice between hands.

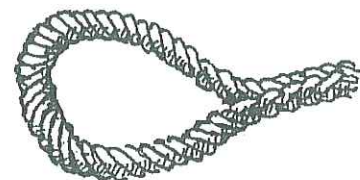

The finished eye splice.

Written by Peter Brooks
Illustrated by Doug Mountford

Back - to - basics

Basic . . . rope-end whipping

In the teaching of rope-work there is a maxim that cannot be stressed often enough — look after your rope and it will look after you, mistreat it and it will probably fail you at the most catastrophic moment possible. Rope should be respected, therefore, and when the cost of new rope, whether of natural or man-made materials, is added into the equation, the case for taking care of your rope becomes indisputable.

While respecting the rope generally, many people fail to protect the rope-ends, with the result that they quickly unravel and more and more of the rope soon becomes unusable and useless. Whipping the ends of all ropes is the answer. This does not take particularly long but will extend the life of your ropes immeasurably.

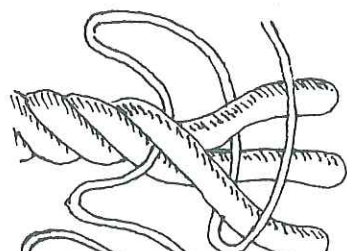

Sailmaker's whipping

Open lay of rope and pass whipping cord through and back to form a loop around one strand.

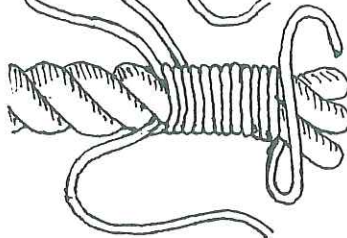

Using running end, whip normally to desired length.

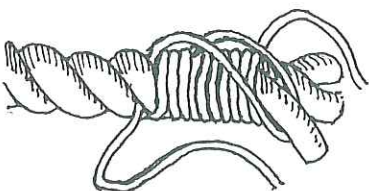

Pass loop over top of same strand it surrounds lower.

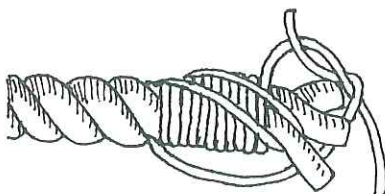

Tighten down *securely* into rope-head, trapping whipping end. Carry standing end up whipping and tie, as deep into rope-head as possible, to running end.



Roll underfoot to check whipping and seat it properly into lay of rope.

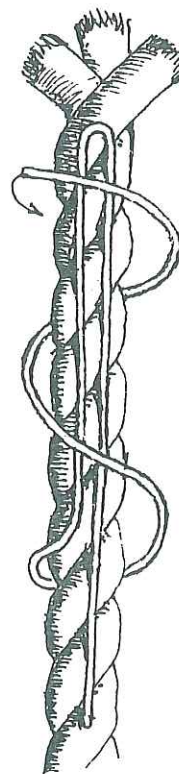

Common whipping

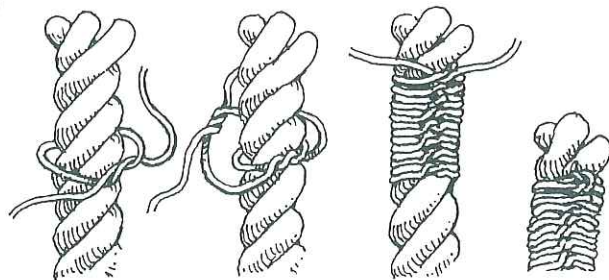
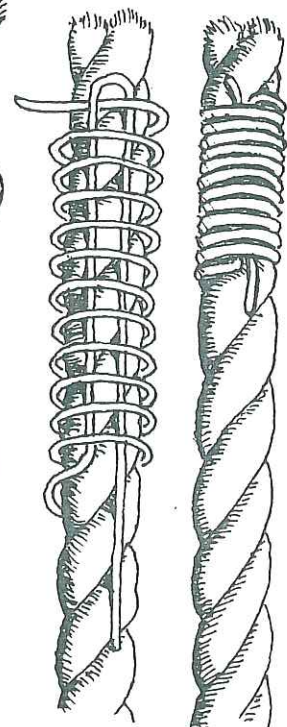

West Country whipping

Heat-sealing ropes

Melting the end-fibres of man-made rope together into a blob is an effective 'seal' but can increase the circumference of the rope which can make it difficult to thread through holes, blocks and so on and any sharp edges left can be very dangerous. A well-done whipping is just as effective and rather safer.

Written by Peter Brooks
Illustrated by Doug Mountford

Back - to - basics

Basic... first aid I Roller bandaging

Most artists, if asked to cartoon a Scout practising first aid, would caricature the 'patient' mummified in bandages from head to foot with just a pair of eyes showing — and in some Troops this image may not be too far from the truth! Joking aside, first aid is one of the basic ingredients in Scout training — rightly so! — but it is also important that Scouts are taught the correct techniques, as well as what to do and what not to do.

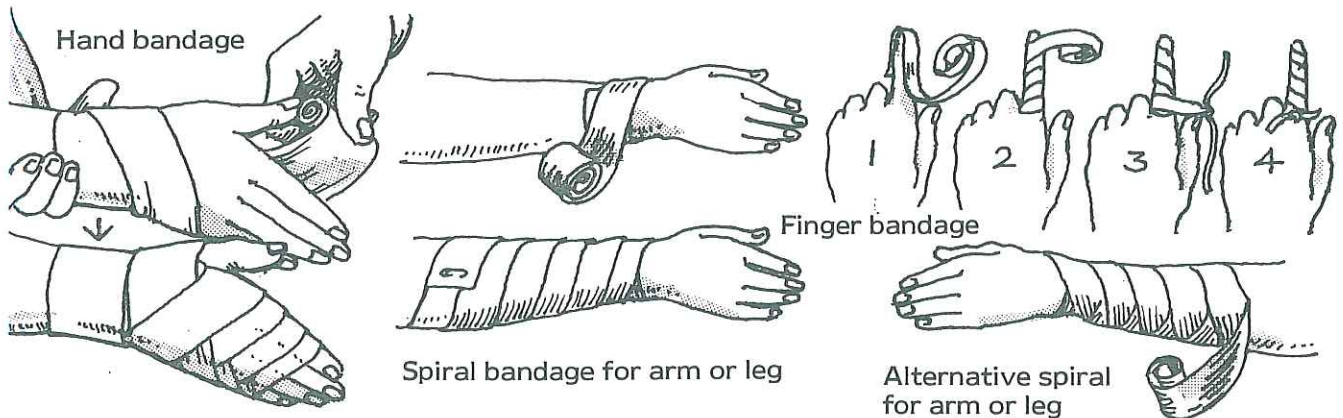

Applying tubular gauze bandages to finger wounds

1. Cut a length of gauze approximately $2\frac{1}{2}$ times as long as the area to be covered. Push the whole length onto the applicator.

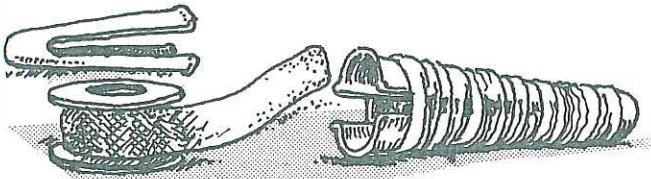

2. Push the applicator gently over the pre-dressed wound.

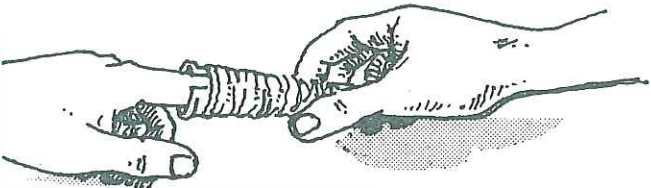

3. Slip the inner end of the gauze off the applicator and hold in place with one hand. Slowly pull back the applicator to leave one layer of gauze in place.

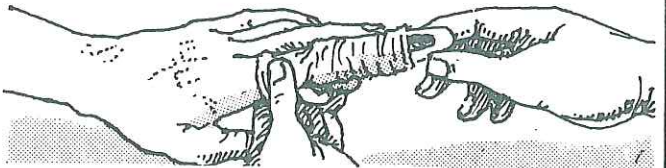

4. When clear of the finger, twist the applicator one turn and push back onto the limb again. Withdraw empty applicator and secure the end of the gauze with adhesive tape.

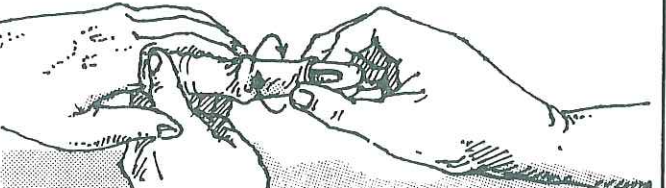

Securing a roller bandage

Fold the end of the bandage under and secure with a small safety pin, adhesive tape or bandage clip. If you are applying a thin gauze bandage, slit down the centre of the last 15cm (6in), tie a half knot (which will stop the slit lengthening) and, using a reef knot, tie the ends around the limb.

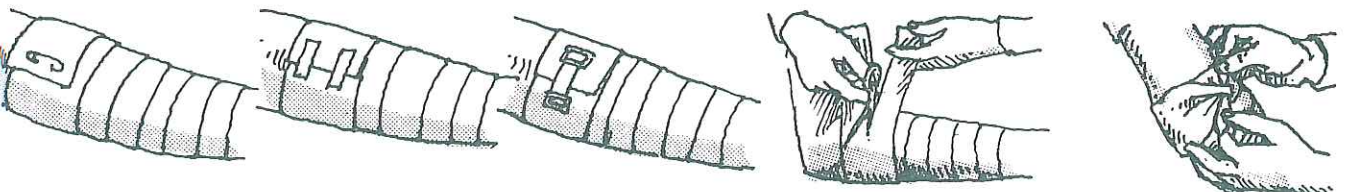

Written by Peter Brooks
Illustrated by Doug Mountford

Back - to - basics

Basic . . . first aid II Slings and triangular bandages

It is an oft-repeated fact that all the items of the original Scout uniform had an alternative use — the big hat was ideal for carrying water, for instance, the scarf could double as a bandage, the staff was absolutely ideal for fighting off mad dogs and so on and so forth. While, with the various changes made to the uniform, most of these items have disappeared either completely or at least from everyday use, the scarf remains and maintains its dual role.

Although a scarf can never be described in medical terms as a sterile dressing and would need to be replaced by one such at the very first opportunity, it is useful in an emergency, not only for supporting an arm- or collarbone-fracture or injury but also for a variety of other wounds. . .

Knee bandage

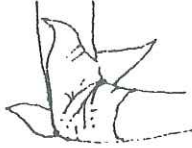
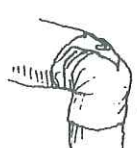
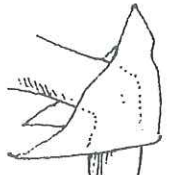

Elbow bandage



Foot bandage



Hand bandage



Large arm-sling



Arm should be slightly raised



Ends of fingers should protrude

Knot (reef) on injured side



Elevation sling

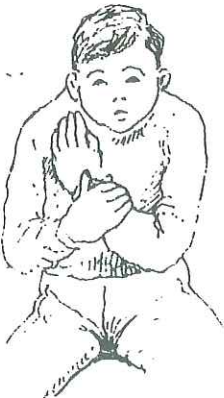

Head bandage



Back - to - basics

Basic . . . weather

In the United Kingdom, we seem to take a peculiar pride in the variability of our weather and, likewise, we are never satisfied with it — we are always complaining that it is too hot, too cold, too wet or too dry. We talk about our weather and its unpredictability almost incessantly and we complain like the dickens about the weatherman — he's always wrong and even on the rare occasions that he isn't, we don't believe his predictions so he's on a loser again!

However, basic weather prediction is not difficult if one masters just a few simple premises. The British weather system is governed by two features — Depressions (low pressure areas, also known as cyclones) and anti-cyclones (high pressure areas).

Depressions (Lows)

In winter, depressions tend to bring warmer but wetter weather with plenty of cloud cover. The wind is often quite strong.

In summer, the same cloud cover and 'wetter' aspects apply.

Generally, weather brought by depressions is unsettled and changeable.

Anti-cyclones (Highs)

In winter, the weather tends to be settled with little cloud but, in consequence, it can be very cold, particularly at night.

In summer, high pressure areas also bring little or no cloud, little or no wind and the temperature goes up — although, as in winter, it does get rather cold at night as there is no cloud cover to keep the heat in.

Generally, anti-cyclones bring settled weather that usually stays for several days.

Wind

As the wind blows from different directions, it brings air of varying temperatures and differing weather.

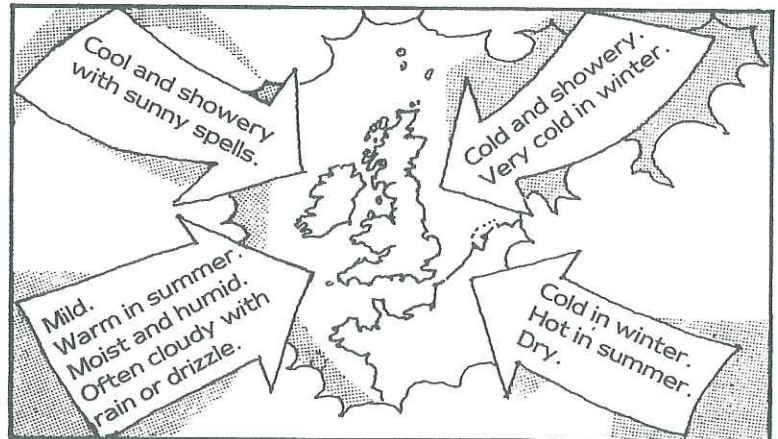

Beaufort scale

The following scale is widely used for describing the wind speed. Simply by using the scale number ('Wind — Force 6' for example) mariners, meteorologists and others who regularly 'use' weather information will know what to expect — it is, in fact, a form of verbal shorthand.

Scale number	M.P.H.	Effect
0	Less than 1	Smoke rises vertically.
1	1-3	Direction shown by smoke, not by vanes.
2	4-7	Wind felt on face, leaves rustle, vanes move.
3	8-12	Leaves and twigs in constant motion, light flags extended.
4	13-18	Dust and small paper raised, small branches move.
5	19-24	Small trees in leaf sway.
6	25-31	Large trees move, whistling telegraph wires, umbrellas difficult to control.
7	32-38	Whole trees move, inconvenience in walking against wind.
8	39-46	Twigs break off trees, walking is difficult.
9	47-54	Slight structural damage to buildings, branches break.
10	55-63	Trees uprooted, buildings sometimes blown down.

Note: This scale goes up to 17 but such winds are seldom experienced in mainland Britain.

Written by Peter Brooks

Illustrated by Dave Munn

Back - to - basics

Basic ... estimation

Whereas, with practice, one can become quite good at estimating distances (even though this is usually only when giving directions — 'The station? Yes, take the next road on the left and it's about 2 kilometres along on the right') there are few enough opportunities to develop a skill at estimating the height of something. Likewise, short distance estimation is often inaccurate and if, say, during a pioneering exercise, your thrown line drops short of the island by just three feet — three unreachable feet — when you confidently pronounced that it would reach easily, it can be more than a little embarrassing.

Estimating height — Method 1

For this method you will need a 1-metre rule and a friend.

For tall buildings, pace 99 steps away from the building, place the rule vertically on the ground and ask your friend to hold it so. Go one pace further and lie flat on the ground, looking past the rule to the top of the building. Ask your friend to slide his finger down the rule and stop him when you see his finger line up with the top of the building. The height of his finger above ground *in centimetres* equals the height of the building *in metres* — so if his finger is at 43 centimetres on the rule then the building is 43 metres tall.

For small buildings, trees and so on, as above but pace just 9 steps. Height of finger above ground *in centimetres divided by 10* equals height of building/tree *in metres* — so 88 centimetres on the rule means that the building/tree is 8.8 metres tall.

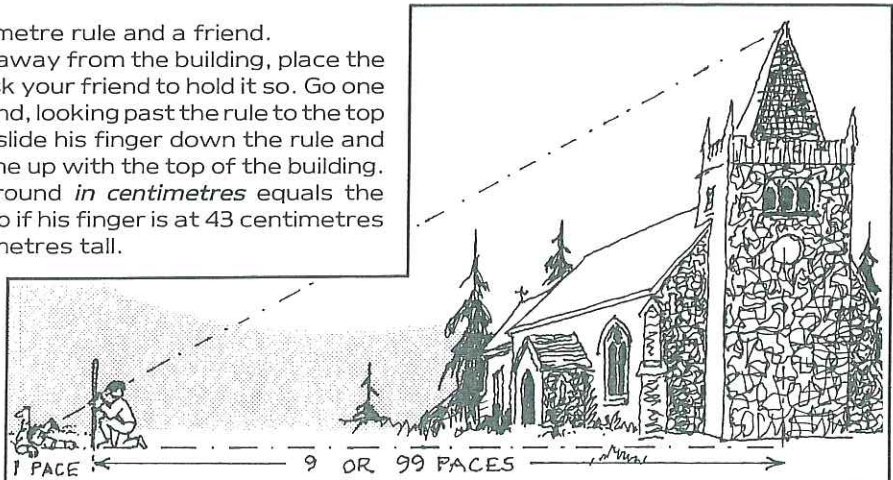

Estimating height — Method 2

This method is not so accurate as the one above but will give you a reasonably good idea. You will need a friend and a stick, pencil or similar. From a reasonable distance — but accurate distance is not necessary — hold the stick vertically and extend your arm horizontally towards the tree. Move the stick up or down until the top aligns with the top of the tree and your thumb-nail is at the trunk base. Twist your hand through 90° — thus laying the 'tree' down — and position your friend in line with the top of the 'tree.' Measure off the distance between him and the foot of the tree.

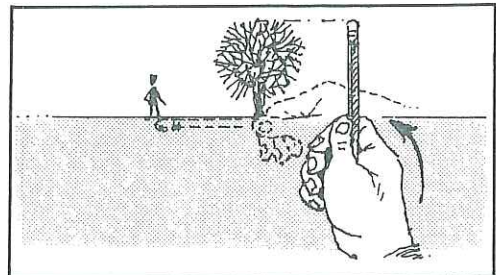

Estimating height — Method 3

A tree is to its shadow as a staff (or stick) is to *its* shadow.

Estimating uncrossable widths

Locate an object on the opposite bank of, say, the river (a). Stand opposite (b) and walk 40 paces along the bank (to c) and mark this point with a vertical stick. Walk a further 20 paces (to d) and turn at right-angles to the bank. Walk away from (d) to a point at which the stick (c) and the object at (a) align, this is point (e). The distance from (d) to (e) is half the width of the river.

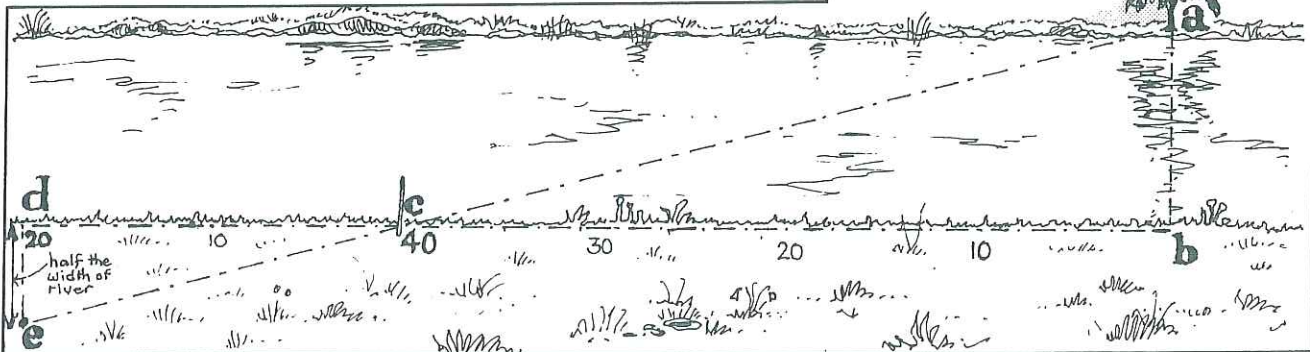
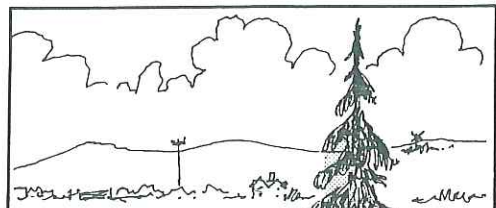

Written by Peter Brooks
Illustrated by Doug Mountford

Back - to - basics

Basic . . . signalling

Among the many misconceptions lodged firmly in the public mind is the belief that Scouts, when they are not tying knots or lighting fires, spend the rest of their time on the tops of hills frantically waving flags at each other (semaphore, in fact).





























Although patently untrue (nowadays, anyway), being able to signal — accurately and understandably — certainly does have its uses. While we are not suggesting that this is something you will find a need for on anything like a regular basis, there will be occasions when you will be able to save yourself a considerable amount of time and, probably, effort as well, by possessing this rudimentary skill.

Flags are not always necessary but they are easier to read. Below are the positions *as seen by the receiver*.

Points to remember:

- Your movements should be precise — the flag angles are important so don't let your arms waver about, strike a position for each letter and hold it.
- The sender begins by making the 'Attention' sign ('U' with arms waved up and down). Receiver responds with 'General Answer' ('A' or 'C' — see Note below). Sender makes 'Direction' sign ('J') and receiver acknowledges. Sender then commences message.
- At the end of each word, sender drops arms to 'Ready'. Receiver acknowledges its intelligible receipt with 'General Answer' ('A' or 'C').
- If a mistake is made, send a series of 'E's until acknowledged. Then send correct message.
- All messages end with 'A' 'R'.
- Numeral sign is used at start *and finish* of numeral transmission.

Note: Either of these letters is acceptable. There is no clear favourite from the eight reference sources we consulted.

A/1  (and 'General Answer' / 'Acknowledge')	B/2 	C/3  (and 'General Answer' / 'Acknowledge')	D/4 	E/5 	F/6 	'G/7 
H/8 	I/9 	J  (and 'Direction' sign)	K/O 	L 	M 	N 
O 	P 	Q 	R 	S 	T 	U  (and 'Attention' sign)
V 	W 	X 	Y 	Z 	 'Ready' sign.	 'Numeral' sign

Written by Peter Brooks









Back - to - basics

Basic . . . Troop control

The word 'discipline' seems to have dropped somewhat from favour in the last decade or so, indeed, recent news suggests that it may soon be against the law for parents to strike their children — whether that is a good thing or not is something upon which we will not comment.

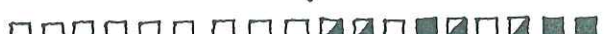
There is, however, still a need for certain levels of discipline, not least of which is in the area of Troop control. The Scouter who continually shouts at his lads to effect control is doing it wrong! So, too, is the perpetual whistle-blower! Far better, is to institute a system of hand signals such as those illustrated below. It should be stressed, however, that these signals should not be augmented with any verbal communication whatsoever. The brighter ones amongst your lads will soon realise that, if you just stand there and wait, it is their own time that they are wasting and they will soon whip the others into line.

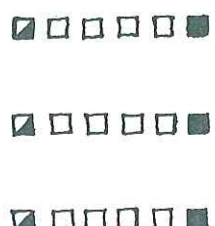
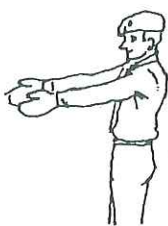
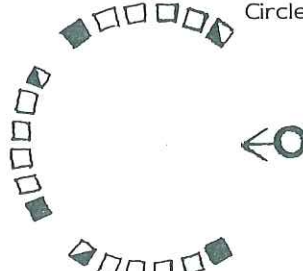
Try it, it's worth the effort and self control!

<p>In line, in Patrols</p>  <p>↓</p> 	<p>Quiet, stay where you are</p> 
<p>One line</p>  <p>Shortest Tallest</p> <p>↓</p> 	<p>Horseshoe</p> 
<p>Relay formation</p>  	<p>Circle</p>  
<p>Key:</p> <ul style="list-style-type: none"> Scouter ←○ Patrol Leader ■ Assistant Patrol Leader ▣ Scout □ 	<p>Hollow square</p> 

Written by Peter Brooks
Illustrated by Doug Mountford

Back - to - basics

Basic . . . Patrol corner and box

Patrol Time is an important feature in any Troop's programme as this is the opportunity for them to discuss what activities they would like to do, where and when they will go off for a Patrol camp, air any grievances for onward transmission to the Patrol Leaders' Council and so on.

Ideally, this meeting should be held in private and while it is not possible, in many Troops' situations, for each Patrol to meet in a different room, a degree of privacy can be achieved relatively easily with a Patrol screen.

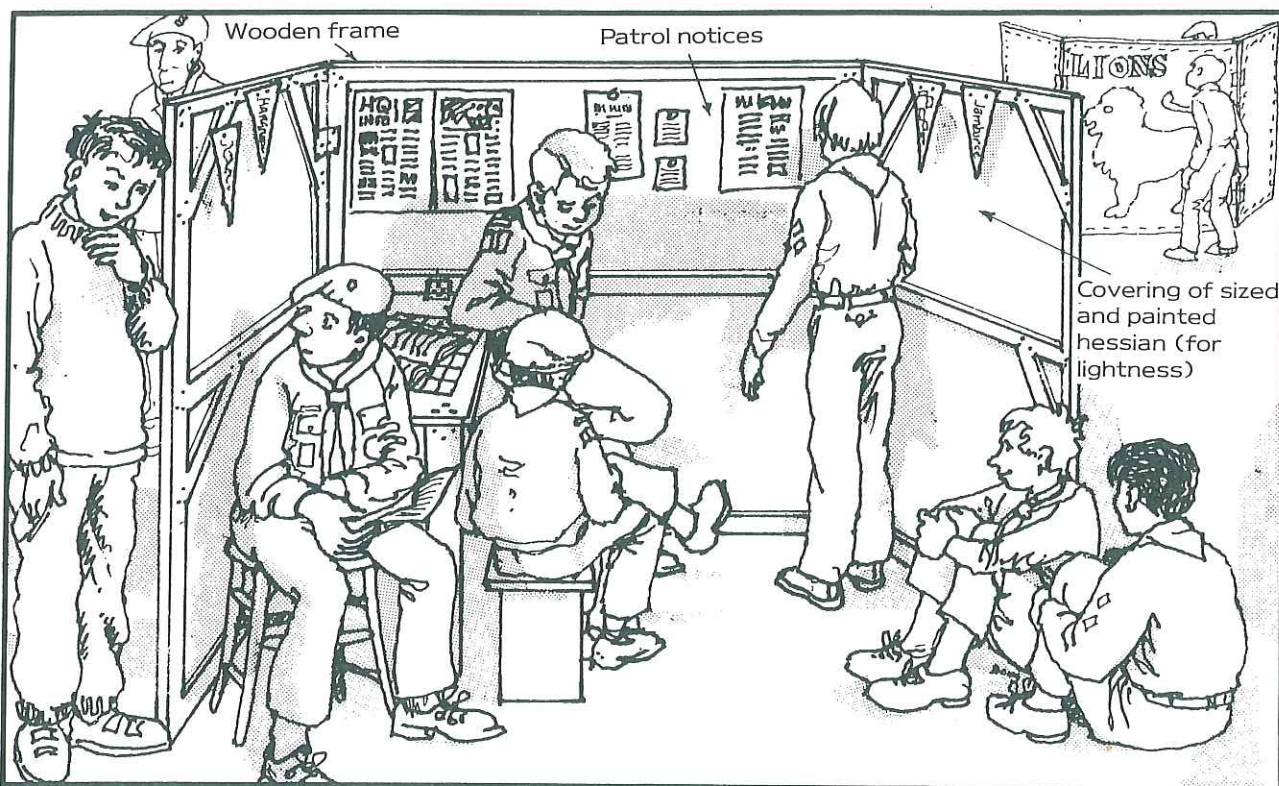

Patrol box

Every Patrol should have its own Patrol box. This is generally a stout wooden box, usually lockable, which is often decorated in the Patrol colours and adorned with the Patrol emblem. In it is kept a variety of items which the Patrol is likely to need during Meetings and when they are away at camp. It is up to the Patrol to maintain its box and add to the list suggested here any items that they think necessary or desirable.

- 6 knotting/lashing ropes
- Triangular bandage (for practise only)
- Chalk
- Notebook/blank paper
- Pencils
- Rule
- Local Ordnance Survey map
- Compass
- Adhesive tape
- Drawing pins
- 1 copy *Scouting for Boys*
- 1 copy *The Fun of Scouting*
- 1 copy *Challenge and Adventure*
- 1 copy *Scout Proficiency Badges*

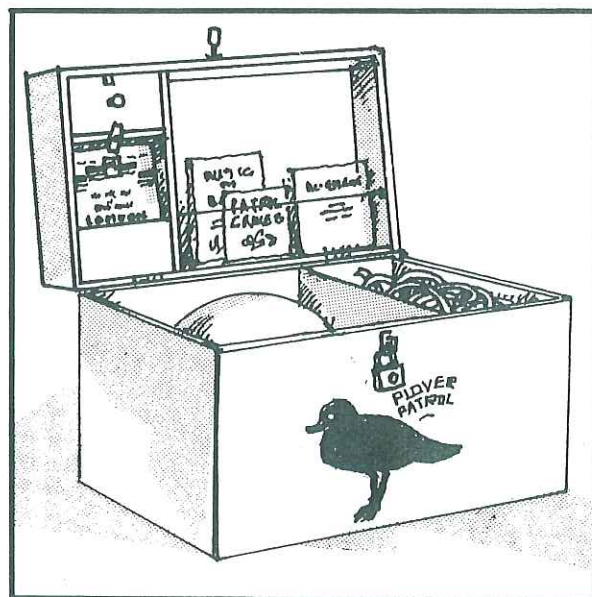

Written by Peter Brooks
Illustrated by Doug Mountford

Back - to - basics

Basic... B.-P. — Part 1

Many books have been written about Baden-Powell, but few Scout Leaders have the time to read them to assimilate the knowledge necessary to brief their new recruits on the 'B.-P. story' as the Scout Badge requires. Hopefully, the following summary will help.

February 22, 1857 saw the birth of the newest addition to the Powell family of West London. Robert Stephenson Smyth, as he was christened (the first two names being in honour of his godfather, the son of George Stephenson, the designer of the first successful locomotive, and famous in his own right as an engineer and bridge builder) joined the already large (although there were, indeed, two further children still to come) family of an ageing Oxford professor and the daughter of a naval Commander.

Regrettably, Professor Baden Powell died before Robert reached the age of three and, as a sign of her respect and devotion, Mrs. Powell had the family surname changed by deed-poll to incorporate her late husband's Christian name (the one unfortunate consequence of this action was that her youngest son then became Baden Baden-Powell — unfortunate, but he had to put up with it!).

Life was difficult in those early days for the Baden-Powell family but Mrs. Baden-Powell was a determined woman who knew that nothing was going to stop her children from being successful.

For the next ten years, life for young 'Stephe' (as Robert was known to the rest of the family) can best be described as unexceptional. Until, that is, the excellent 'connections' so assiduously set up by his mother, started to pay off — the Duke of Marlborough nominated him for a scholarship as a Gownboy Founder to Charterhouse School in London. Here he thoroughly enjoyed himself and soon became popular among his class-mates.

But it was when, in 1873, the school moved to Godalming, in Surrey, that B.-P. (as his chums had dubbed him) found life improving even further. Close to the school was a woodland wilderness known as 'The Copse', which the headmaster had placed strictly out of bounds. When he wanted to be alone B.-P. would 'escape' to The Copse and imagine himself as an Indian scout or a hunter. Teaching himself, he learned how to track and trap animals, how to cook them on a smokeless fire (so that the smoke didn't betray the fact that he was there) and how to evade 'capture' when his schoolmasters came searching the forbidden territory — he quickly realised that searchers seldom look up but concentrate their attention on the ground so he climbed up into the trees and hid among the leaves.

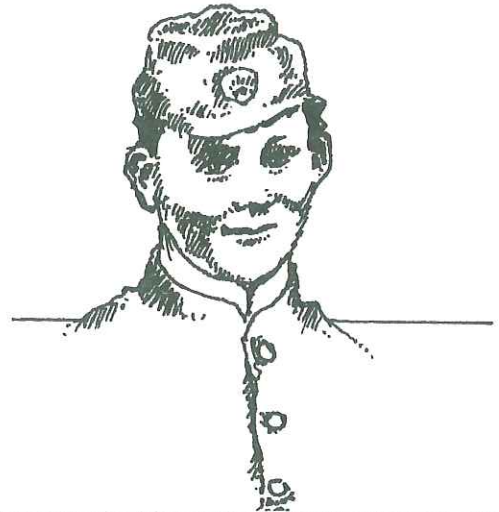

Being not of scholarly bent B.-P. did not excel in his school studies, in fact his performance was rather less than impressive and when the time came to leave school he had no clear idea of what he should do for a career. He was, however, particularly good at acting and drawing but any ideas he might have entertained of making a career in either of those professions were ignominiously and very quickly squashed by the indomitable Mrs. Baden-Powell — no son of hers was going to be an artist or an actor!

After failing the entry examinations for Oxford's Balliol and Christ Church Colleges and with no idea further than that he would like to travel, B.-P. came upon an advertisement for an Open Competition Examination for commissions in Her Majesty's Army. It seemed worth a try so he sent his name in and for nearly two weeks, in July 1876, he sat a variety of examinations.

To everybody's amazement (not least his own) B.-P. surpassed all expectations and, out of the 718 entrants, he had finished fourth in the placings for the infantry regiments and third in the cavalry listings.

The decision was made — B.-P. was in the Army and within a matter of weeks had been commissioned as a Sub-Lieutenant and gazetted to the 13th Hussars.

Written by Peter Brooks
Illustrated by Doug Mountford

Back - to - basics

Basic . . . B.-P. — Part II

Baden-Powell's army career was, for the most part, typical of a young officer of those days and he saw service in India, Afghanistan, South Africa (twice), Malta and the Gold Coast (since renamed Ghana).

Several things, however, stood him apart from his peers: he was an extremely able officer — recognised by his rapid promotion (he had reached the rank of full Colonel by the time he was 40) — who was also popular with his men, he was a talented artist, actor (on one occasion when he was, in fact, still a very junior officer, he strode down the aisle during a regimental concert, in the full dress uniform of a Major-General, to the complete astonishment of his commanding officers (who knew there was a new general in the vicinity but had not met him). Then, without further ado, he jumped up onto the stage 'to address the men' and promptly sang Gilbert and Sullivan's *I am the very model of a modern Major-General*. Everyone immediately realised who it was and gave him a thunderous ovation!) He was also a keen sportsman, expert horseman and all-round good egg!

His ability as a scout (in the true military sense of that word) was also recognised and he quickly built an enviable, but well justified, reputation. Probably the most famous of his scouting exploits is the time when, upon being sent to spy out the enemy's strength and disposition he donned the disguise of a butterfly catcher and, complete with net and sketchpad, set off into the hills. Wars were fought in a different and more gentlemanly way in those days, and the enemy patrols paid no heed to the traveller they stopped, only briefly, who prattled on about the abundant lepidoptery thereabouts and who showed them the specimen drawings in his pad — indeed, after a minute or two they were only too keen to send him on his way and get rid of him!

However, had they studied his drawings more carefully they *might* have noticed that the markings of one butterfly bore more than a passing resemblance to the gun positions of their own fortress! But so good was the butterfly catcher disguise and so tedious his incessant ramblings about butterflies that he, his drawings and his invaluable intelligence of the enemy positions returned intact!

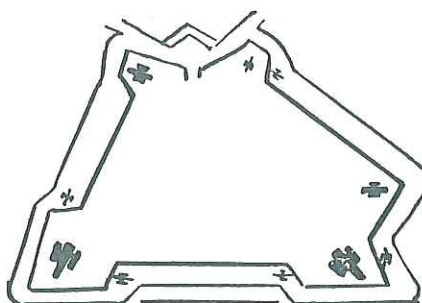
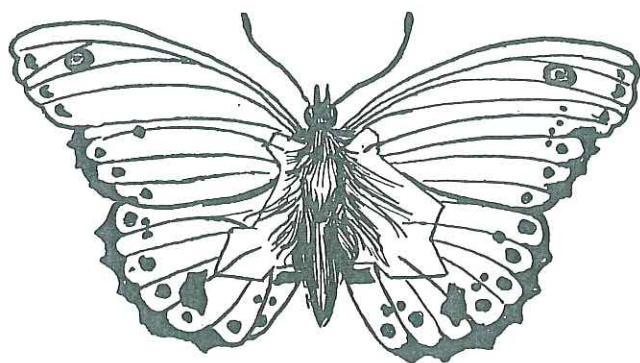
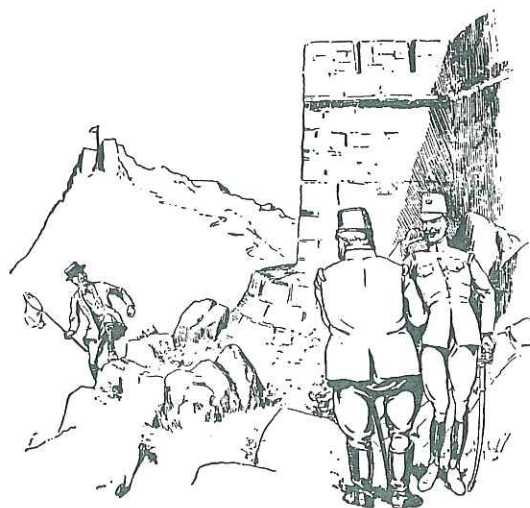

The marks on the wings reveal the shape of the fortress shown here and the size of the guns.

FORTRESS GUNS.

FIELD GUNS.

MACHINE GUNS.

Stories of B.-P.'s cunning and ingenuity abound but it was about this time that he started developing his ideas for training individual soldiers in the art of stalking, spying and working in small groups (or 'patrols' as he called them) under the direction of an officer or non-commissioned officer (sergeant, corporal and so on).

What he taught his men, and the way in which he did so, brought into the lives of ordinary soldiers a new sphere of activity, an interest which caught their imagination and lifted them above the drudgery and boredom which was the existence of a soldier in the nineteenth century. The tests he devised stretched his men both mentally and physically, and to those who successfully completed this training he awarded an arrowhead badge — obviously the forerunner of today's Scout Badge.

As a result of the success of this project, B.-P. wrote *Aids to Scouting* — one of many books he wrote while in the army — which was then accepted as almost a 'training handbook' for many years after.

The story of B.-P.'s defence of Mafeking will feature in a later *Back-to-basics*.

Written by Peter Brooks
Illustrated by B.-P.

DaCK - to - basics

Basic . . . B.-P. — Part III

While the pros and cons of whether Mafeking should ever have been defended or not are still being argued (an argument which it is unlikely will ever be resolved satisfactorily), the fact remains that it was defended and that the commander of the defending force — B.-P. — emerged as a national hero upon the town's relief. The ingenuity, resourcefulness, stoutheartedness and guile he employed typified what was regarded as the British Empire's 'bulldog spirit' and gave the British public an event to celebrate during a period of the Boer War which was, at that time, not going her way.

Mafeking was a small, almost insignificant, town, the total white population of which — including B.-P.'s soldiery — numbered just short of 2,000. The besieging Boers, a force estimated to be over 9,000 strong, were held at bay for a total of 217 days (although, said as nine months it sounds considerably longer!).

To be fair, it appears that B.-P. knew well in advance that Mafeking would be besieged and was able to make plans accordingly, which included sending over 200 women and children south, by armoured train (the railway ran through the town), to the safety of Kimberley. Likewise he was able to have an observation tower built over the solicitor's office he took over as his headquarters and a hole cut in the office's roof for a voice-pipe.

One of his other little preparatory ruses involved 'mining' the whole area surrounding Mafeking. B.-P. had hundreds of black wooden boxes constructed (and, unbeknown to almost everybody, filled with sand!) and buried around the whole town. Then, to reinforce the point, he announced that one mine would be 'tested' at such-and-such a time and, having cleared all the people from the section of town that overlooked the designated area, the wily old fox ignited a stick of dynamite! A passing cyclist, unhurt in the blast but more than a little shocked, pedalled off like fury, convinced that he had set the 'mine' off and so the story gained credence and the town, together with the many spies and traitors it contained, believed that they were surrounded by a minefield and this news was surreptitiously passed across to the Boers.

Such stories abound — like the time they ringed the town with 'pretend' barbed wire by knocking in the posts and then 'unreeling' the 'wire' and 'fixing' it to the posts — a great wheeze except that they had to remember to 'step over' it each time thereafter! They got away with this because the Boers were far enough away not to be able to see clearly whether there was any wire there or not.

Another ploy led the enemy to believe that the whole town was surrounded with searchlights. The fact of the matter appears to be that B.-P. had *one* 'searchlight', which was a biscuit-tin with a lantern in nailed to the top of a tall pole. This was lit and shone around in one position, extinguished and rushed, bodily, across town to another location and re-lit and so on all night long!

As all sorts of supplies began to run low, improvisation became the name of the game. One such commodity was money. After all, the men still had to be paid and the town had to continue to trade. People couldn't do without money as they could other items so, ultimately, there was only one alternative — issue new money, so B.-P. ordered some to be printed. Postage stamps also ran short so he had these printed too, and as it was not possible to print the queen's head on them, he had his own portrait incorporated (although it is reported that Queen Victoria was extremely displeased when she came to hear of this!).

But it was during the siege that what was probably the seed of the whole Scout Movement was planted. With a comparatively small force at his disposal and the whole town to guard, B.-P. quickly realised that he would have to use boys to do some of the jobs that were currently being done by his men. The jobs of carrying messages, acting as look-outs and so on they handled well — so well, in fact, that, as time went on, they were trusted with more and more important tasks.

This use of boys, together with their initiative and, more importantly, the fun and use they got out of it, sparked a thought in B.-P.'s head.

And the rest, as they say, is history!



Written by Peter Brooks
Illustrated by B.-P.

Back - to - basics

Basic . . . Brownsea Island

The fact that B.-P. held a camp on Brownsea Island from which sprang the genesis of Scouting, is well-known. What is not such common knowledge, though, is the finer detail of that camp. Here are a few of the answers . . .

The idea for the camp can be traced back, directly, to a comment made by B.-P. at a country house weekend party in 1906. In that comment he expressed his concern that there were more than one and a half million boys in the country who were outside the range of 'good influences'. Some discussion ensued and it was suggested that B.-P.'s army training manual *Aids to Scouting* might be adapted to be suitable for boys. In considering this, B.-P. quickly realised that 'thinking' the idea might work was not good enough — it would be far more practical to actually try the idea out, and what better way than under camp conditions?

The site

Finding an out of the way site (remember, B.-P. was still a popular, nationally known figure and the Press would be very keen to get wind of a 'new' idea such as this) was a bit of a problem until, that was, B.-P. remembered an island he had sailed around as a youngster (which, by good fortune, was owned by a friend he had made that summer). It was ideal and permission was granted as soon as the request was made.

The campers

Who to take was a comparatively simple problem which he solved in two ways. Deciding that 20 was about the right number he first approached some of his army friends, most of whose sons were at public school, and then, to achieve a balance, he needed ten working-class boys and these he found not, as is usually reported, from the East End of London but instead from The Boys' Brigade Companies of Bournemouth and Poole (B.-P. had met Sir William Smith, the Brigade's Founder, previously and his request for help was easily met). At the last moment, B.-P. agreed to take his young nephew as well, so there were, in fact, 21 boys there. Young Donald was not attached to any Patrol but acted, instead, as his uncle's adjutant.

Much of the practical organisation of the camp (the assembling of the gear and tents, amassing the food provisions, hiring a professional cook, moving the gear over to the island, having the tents pitched ready for occupation and generally ensuring that all was in readiness) was undertaken by Henry Robson, the local Boys' Brigade Captain, and a good degree of the success of the camp is attributable to him.

The programme

The programme of the camp, however, was entirely B.-P.'s — it was his show, after all. His outline of events, plus the daily timetable they ran to were planned like this:

1st day — Preliminary — After settling into camp, formation of Patrols and distribution of duties, orders and so on, each subject of the course was explained with demonstrations.

Patrol Leaders received special instruction in the field for them to impart subsequently to their Patrols.

2nd day — Campaigning — Camp resourcefulness, hut and mat-making, knots, fire lighting, cooking, health and sanitation, endurance, finding way in strange country, boat management.

3rd day — Observation — Noticing and memorising details far and near, landmarks and so on, tracking, deducing meaning from tracks and signs, training eyesight.

4th day — Woodcraft — Study of animals and birds, plants, stars and so on, stalking animals, noticing details of people, reading their character and condition.

5th day — Chivalry — Honour, code of the knights, unselfishness, charity and thrift, loyalty to the King and to employers and officers, practical chivalry to women, obligation to do a 'good turn' daily.

6th day — Saving life — From fire, drowning, sewer gas, runaway horses, panic, street accidents, improvised apparatus and first aid, Albert Medal.

7th day — Patriotism — Colonial geography, history and deeds that won the Empire, our navy and army, flags, medals, duties as a citizen, marksmanship, helping police and so on.

8th day — Games — Sports comprising games or competitive practices in all subjects of the course.

Daily programme

6 a.m.	Turn out. Air bedding. Milk and biscuits.		followed by prayers. Breakfast.	6 p.m.	Camp games.
6.30 a.m.	Exercises.	9 a.m.	Scouting practices.	7.15 p.m.	Rub down and change.
7 a.m.	Notices as to today's activities with demonstrations.	12 noon	Bathing.	8 p.m.	Supper.
		12.30 p.m.	Lunch.	8.15 p.m.	Camp fire yarns. Short exercises.
7.30 a.m.	Clean camp.	1-2.15 p.m.	Rest.	9.15 p.m.	Prayers.
7.55 a.m.	Parade, Flagbreak	2.30 p.m.	Scouting practices.	9.30 p.m.	Turn in. Lights out.
		5 p.m.	Tea.		

Written by Peter Brooks

Back - to - basics

Basic . . . Movement history

Wednesday, January 15, 1908, was a day whose place in the history of Scouting will never be forgotten. Like so many other 'memorable' days, its 'memorableness' was not apparent then or, indeed, for some little time afterwards. But as anyone with an inkling of Scouting's history will know, it is the day when it all began — indirectly at least — for that is the day on which the first part of *Scouting for Boys* went on sale. Thereafter at fortnightly intervals, five further parts hit the bookstalls and so great was the impact of that little literary work that by the time Issue four came out the demand was exceeding the number of copies printed — a best-seller even by today's standards!

Just how the Movement germinated thereafter is fairly well known: Patrols forming themselves and then banding together and seeking adult leadership, Troops forming, public meetings to promote Scouting and seek support for it and so on. Within just 18 months of the appearance of *Scouting for Boys*, the Movement had already taken its place in the fabric of the nation — proven beyond doubt with the appearance of the cartoon below in *Punch* of September 1, 1909.

So rapidly did things take off that it very quickly became apparent that 'a Headquarters' was necessary and a 'Boy Scouts' Office' was made available by Pearsons, the publishers, in Henrietta Street and, after a year, more permanent offices were rented in Victoria Street, London. Almost ten years later even larger premises were needed and the move into 25 Buckingham Palace Road took place — and, in 1918 became known as Imperial Headquarters (IHQ) or more commonly, 'The Ivory Towers'.

But the Movement's establishment and rapid growth were not restricted to Great Britain. Chile was the first overseas nation to take up Scouting, closely followed by Australia, South Africa, Canada, New Zealand and Gibraltar. This spread continued and was worldwide — by 1922, there were already over one million Scouts — fuelled in part by the many speaking tours undertaken by B.-P. (one of which, to the West Indies in 1912, resulted in his meeting Miss Olave St. Clair Soames whom he married within the year).

1910 also saw the creation of Girl Guides, as a result of a party of young ladies — smartly turned out in Scout hats and scarves and carrying 'poles' — appearing at the Movement's first big public demonstration of its strength, at Crystal Palace, and saying to B.-P. 'Please, Sir, we are the Wolf Patrol of the Girl Scouts, and we want to do Scouting like the boys.'

Pressure was also felt from Scouts' younger brothers and, before very long, this became irresistible. The result was that, in 1916, Wolf Cubs burst upon the scene and (in latter days as Cub Scouts) they have never looked back!

A permanent camp site — initially for Scouts from the East End of London but that didn't last too long — was next on the list of 'wants' and extensive enquiries produced a prime site of some 55 acres on the edge of Epping Forest which was almost ideal. The whole Gilwell Park estate was swiftly purchased by William de Bois Maclaren who promptly gave it over to the Movement — lock, stock and barrel — as a present. Over the Easter weekend of 1919, a party of Scouts camped on the estate (in *The Pigsty* to be precise which is still standing today) and started work on redeveloping Gilwell into what has become the spiritual home of world-wide Scouting.

All this time the Scouting 'explosion' had continued. The story of the unknown Scout's good turn to an American publisher in the midst of a thick London fog in 1909 is true (the story may have been gilded a little over the years but there is little doubt of the facts of the incident and its repercussions). The lad, it seems — with the statement that Boy Scouts didn't take money for doing a good turn — refused a tip for giving William D. Boyce directions when he was lost and this so aroused Boyce's curiosity (as lads of that time just didn't refuse money) that he made enquiries and ended up going home with a trunk full of literature from which grew The Boy Scouts of America. Now they number almost four million Members — was ever a single good turn so repaid?

Not unnaturally, the rate of growth has slowed over the years but the Movement's position — as the largest (by far) youth movement in the world — is unassailable. Currently we have over 16 million Members and estimates — and they can only be that — suggest that over 250 million young people have been Scouts since that January day, long ago, when it all started to happen.



Our Youngest Line of Defence

BOY SCOUT TO MRS. BRITANNIA: 'Fear not, Gran'ma; no danger can befall you now. Remember, I am with you!'

Punch, 1 Sept., 1909

Written by Peter Brooks

Back - to - basics

Basic . . . Chief Scouts — Part 1

The position of Chief Scout of The Scout Association is a very important one, for it is he that is the public figurehead of the country's largest youth Movement. He must command the respect of the whole Movement. He must be a leader to whom all Members can look up. He must inspire confidence and industry. He must be an example. He must keep the Movement in the public eye and up to date. He must be its defender and its greatest advocate. In short (but not wishing to sound in the least cynical) he must be little short of a paragon of virtue!



**The Lord Somers, KCMG, DSO, MC
Chief Scout 1941-1944**

Arthur Herbert Tennyson Somers-Cocks, 6th Baron Somers, was born at Freshwater, Isle of Wight on March 20, 1887. Educated at Mulgrave Castle, Charterhouse and New College Oxford, he joined the 1st Life Guards but cut short his army career to farm in Canada. With the outbreak of the 1st World War he returned home to rejoin his Regiment. He retired from the army in 1924 — two years after having become involved in Scouting.

In 1926 Lord Somers was appointed Governor of Victoria, Australia and became Chief Scout of that State. He led 8,000 British Scouts to the World Jamboree in Holland in 1937. The following winter he helped to put Scouting on a firm financial footing by launching a national appeal. He worked tirelessly for the Movement and when war broke out in 1939 he gave an immediate lead in support of National Service. He recommended that Scouts wore their uniform and wore his in the House of Lords.

**The Lord Rowallan, KT, KBE, MC, TD, LLD, DL
Chief Scout 1945-1959**

Born Thomas Godfrey Polson Corbett in London on December 19, 1895, he was educated at Eton. The 1st World War broke out when he was 18 and he went straight from school into the army, serving at Gallipoli, Egypt and Palestine. He won the Military Cross in France but a severe leg wound put paid to what might have been a brilliant military career. In 1933 he succeeded to his father's peerage.

He joined the Scout Movement in 1922 as a District Commissioner. His involvement with the Movement progressed until, in 1944, he became the Scottish Headquarters Commissioner for the Training of Leaders. Just before the outbreak of the 2nd World War, Lord Rowallan was asked to raise a new Battalion of the Royal Scots Fusiliers which he trained along Scout lines. After Dunkirk he was given command of a Young Soldiers' Battalion and later he was made responsible for training potential officers.

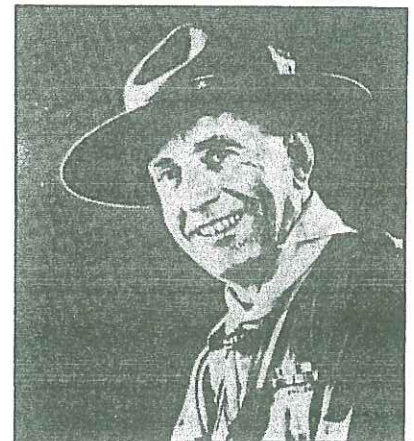

**The Lord Maclean, KT, GCVO, KBE
Chief Scout 1959-1971**

Born Charles Hector Fitzroy Maclean on May 5, 1916, the fourth Chief Scout was educated at Canford School in Dorset. With a regular commission in the Scots Guards he served in the Guards Armoured Division and the 6th Guards Tank Brigade and he saw service during the 2nd World War in France, Belgium, Holland and Germany.

He was a Cub Scout in London in 1924 and after becoming Chief Scout in 1959 he visited some 50 countries to promote the Movement. He was also appointed Chief Scout of the Commonwealth. He succeeded to the title of 11th Baronet of Duart and Morven in 1936 and as the 27th Chief of the Clan Maclean.

He instituted the Advance Party Report in 1966 which shaped the Movement for the future. In 1971 he was given a life peerage by the Queen and was appointed Lord Chamberlain. In July, 1981 he organised the Wedding of HRH Prince Charles and the Lady Diana Spencer.



Written by Peter Brooks

Back - to - basics

Basic... Chief Scouts – Part 2



Sir William Gladstone, Bt, DL, MA
Chief Scout 1972-1982

Sir (Erskine) William Gladstone, great-grandson of the former Prime Minister, William Ewart Gladstone, was born on October 29, 1925. Educated at Eton, he joined the Scouts while at the school. He saw war service in the Royal Navy which he joined in 1943 and, on leaving the service, he gained a degree at Oxford before entering the teaching profession. He became Headmaster of Lancing College in 1961.

Sir William is married to Rosamund Anne Hambro and they have two sons and a daughter. In 1968, Sir William succeeded his father as 7th Baronet. The family home is at Hawarden Castle, Deeside, Clwyd in Wales. He also owns an estate at Kincardineshire, Scotland.

As Chief Scout he took a special interest in the development of Scouting in deprived areas, particularly in the inner cities. In 1979 he was elected Chairman of the World Scout Committee.

His occupations are farming, horticulture and forestry. He is active in church and civic affairs and is a member of the Court and Council of the University College of North Wales.

Major-General Michael Walsh, CB, DSO, DL
Chief Scout 1982-1988

Major-General Michael Walsh was born in Harrogate, Yorkshire, in 1927 and attended Clifton House School where he was a Member of the school Scout Troop. He has the distinction of being the only Chief Scout who was a boy Member in both Cub Scouts and Scouts, and he became a King's Scout. He also holds the Gold Cords which, in their time, were the Movement's highest training award for proficiency and achievement.

He had a distinguished army career rising from the ranks to become a Major-General. He retired from the army in 1981 after holding the position of Director of Army Training. He married Angela Beswick, from Sheffield, and they have two daughters. An active communicant of the Church of England, he has wide ranging interests in the arts, music and sports. He is a qualified Royal Yachting Association Coastal Skipper, holds a Private Air Pilot's licence and is a qualified parachutist.

Major-General Walsh lives in Wiltshire, and, in common with all his predecessors as Chief Scout, travelled widely both in the United Kingdom and Europe to support and promote Scouting

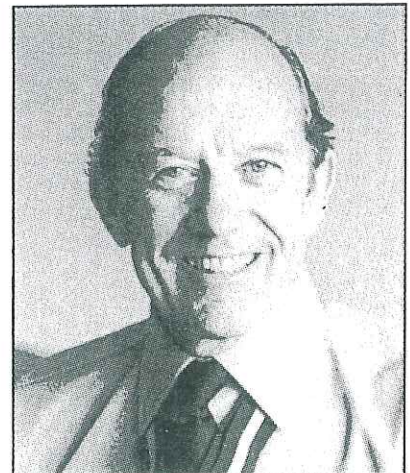

Garth Morrison DL
Chief Scout 1988-1996

(William) Garth Morrison became Chief Scout in 1988 at the comparatively young age of 45. By profession a farmer, Garth had previously served in the Royal Navy. He attended Britannia Royal Naval College in Dartmouth and while there was awarded the Queen's Telescope in 1962, one of six awarded that year. Still in the Navy he then went to Pembroke College, Cambridge, and gained a Bachelor of Arts degree and a year later gained Dartmouth's top award, the Queen's Sword.

Among many other notable achievements, he is a Member of the Society of High Constables and of the Guard of Honour at the Palace of Holyroodhouse and has been Her Majesty the Queen's Deputy Lieutenant in East Lothian since 1984.

Before becoming Chief Scout of the United Kingdom and Dependent Territories, Garth Morrison was Chief Commissioner of Scotland.

Written by Peter Brooks

Back - to - basics

George Purdy Chief Scout 1996 -

George Purdy was born in Northern Ireland in 1942. As an 8 year-old he joined the Cub Scouts and ten years later became an Assistant Scout Leader in the 45th West Belfast. In 1963, he was a founder Leader of the 2nd Donaghadee Scout Troop and 'doubled up' as an Assistant Cub Scout Leader in the 1st Inniskilling. In 1963 he became Scout Leader of the Three Spires Scout Troop in Magherafelt before returning to the 2nd Donaghadee in 1971 where he served in a number of capacities until he became Assistant Group Scout Leader in 1990. He remained with the Group until taking over as Chief Commissioner of Northern Ireland in 1994 - his first ever non-Group Appointment.

In 1983 George led the Northern Ireland Contingent to the World Scout Jamboree in Canada. He has also played a leading role in organising the All Ireland International Scout Camps and was Deputy Camp Chief at Ballyfin in 1993. He was awarded the Medal of Merit in 1983, the Long Service Decoration in 1980 and Bar in 1993. In the 1996 St. George's Day list he was awarded the Silver Acorn.

He joined the Northern Ireland Civil Service in 1960 and is currently Director of Policy and Legislation in the Department of Health and Social Services.

An Elder of the Donaghadee Presbyterian Church, George has worked as a Youth Club Leader, served as a Sunday School Teacher and sung in the choir. He is a founder member of the local Rotary Club.

George is married with two sons, both of whom have been Scouts. Outside of Scouting, his leisure interests include hockey, golf, tennis and bowls.



Written by Peter Brooks



PDF PUBLICATION COMPILED BY

**PAUL CALLEJA-GERA, GSL
15TH CHELTENHAM (SHURDINGTON) SCOUT GROUP**

**BY KIND PERMISSION OF
© THE SCOUT ASSOCIATION
WHOSE COPYRIGHT THIS PUBLICATION REMAINS.**

General Editor: David Easton

© The Scout Association
Reproduced from SCOUTING Magazine
Baden-Powell House
Queen's Gate
LONDON SW7 5JS

Printed: August 1990
Reprinted: November 1997
by Wednesday Press Ltd
Southend-on-Sea, Essex
ISBN 0 85165 242 5

Scouting
Magazine